

Common-Gate Amplifier Example

$K' := 0.002$ $W := 1$ $L := 1$ $V_{TO} := 1.75$ $\lambda := 0.016$ $\chi := 0$

$V_{plus} := 24$ $V_{minus} := -24$ $R_1 := 5 \cdot 10^6$ $R_2 := 1 \cdot 10^6$ $R_D := 10 \cdot 10^3$

$R_S := 3 \cdot 10^3$ $R_s := 50$ $R_L := 20 \cdot 10^3$ $R_p(x,y) := \frac{x \cdot y}{x+y}$ (Jaeger's notation)

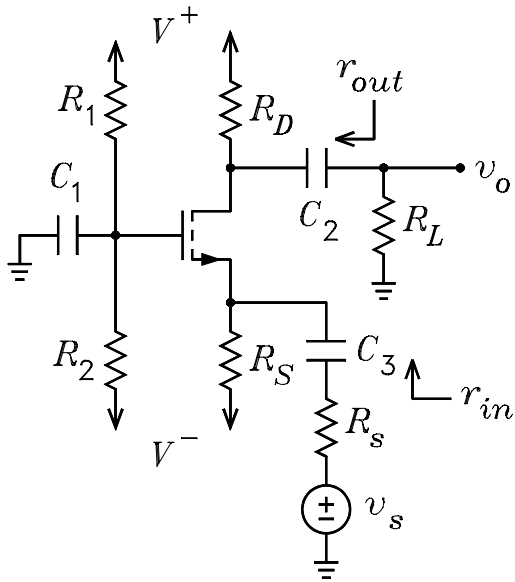

DC Bias Solution

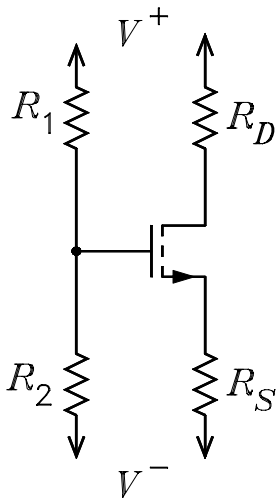

$$V_{GG} := \frac{V_{\text{plus}} \cdot R_2 + V_{\text{minus}} \cdot R_1}{R_1 + R_2} \quad V_{GG} = -16 \quad V_{SS} := V_{\text{minus}} \quad R_{SS} := R_S$$

$$V_1 := V_{GG} - V_{SS} - V_{TO} \quad V_1 = 6.25$$

We neglect the Early effect, i.e. set $\lambda = 0$ to solve for the drain bias current.

$$K_0 := K \cdot \frac{W}{L}$$

$$I_D := \frac{1}{2 \cdot K_0 \cdot R_S} \cdot \left(\sqrt{1 + 2 \cdot K_0 \cdot V_1 \cdot R_S} - 1 \right)^2 \quad I_D = 1.655 \cdot 10^{-3}$$

$$V_D := V_{\text{plus}} - I_D \cdot R_D \quad V_D = 7.454 \quad V_S := V_{\text{minus}} + I_D \cdot R_S \quad V_S = -19.036$$

$$V_{DS} := V_D - V_S \quad V_{DS} = 26.491$$

$$V_{GS} := V_{GG} - V_S \quad V_{GS} = 3.036 \quad V_{GS} - V_{TO} = 1.286$$

Because $V_{DS} > V_{GS} - V_{TO}$, the MOSFET is in the active or saturated state.

Here is an exact solution for the drain current. Note that MathCad requires numbers for everything except the variable being solved for. The drain-source voltage in the equation is $48 - I_D \cdot 13 \cdot 10^3$

$$I_D = \frac{1}{4 \cdot 10^{-3} \cdot \left[1 + 0.016 \cdot \left(48 - I_D \cdot 13 \cdot 10^3 \right) \right] \cdot 3000^2} \cdot \left[\sqrt{1 + 4 \cdot 10^{-3} \cdot \left[1 + \left[0.016 \cdot \left(48 - I_D \cdot 13 \cdot 10^3 \right) \right] \right] \cdot 6.25 \cdot 3000} - 1 \right]^2$$

.0017157743653358533060 This is the exact solution for I_D including the Early effect. We will use the approximate solution for the ac analysis below.

$$\frac{I_D - .0017157743653358533060}{.0017157743653358533060} \cdot 100 = -3.567 \quad \text{This is the percentage error in neglecting the Early effect in solving for the drain current.}$$

Now for the ac solution.

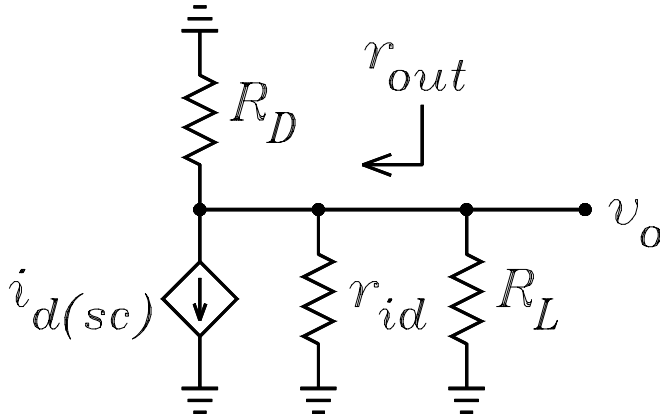

$$K := K_0 \cdot (1 + \lambda \cdot V_{DS}) \quad K = 2.848 \cdot 10^{-3} \quad g_m := \sqrt{2 \cdot K \cdot I_D} \quad g_m = 3.07 \cdot 10^{-3}$$

$$r_s := \frac{1}{g_m} \quad r_s = 325.758$$

$$r'_s := \frac{r_s}{1 + \chi} \quad r'_s = 325.758 \quad \text{No body effect because the body lead is connected to the source lead. This is equivalent to setting } \chi = 0 \text{ in the equations.}$$

$$r_0 := \frac{\lambda^{-1} + V_{DS}}{I_D} \quad r_0 = 5.378 \cdot 10^4 \quad R_{ts} := R_p(R_S, R_s) \quad R_{ts} = 49.18$$

$$r_{id} := r_0 \cdot \left(1 + \frac{R_{ts}}{r'_s} \right) + R_{ts} \quad r_{id} = 6.195 \cdot 10^4$$

$$v_s := 1 \quad \text{This makes the gain equal to } v_o.$$

$$v_{ts} := v_s \cdot \frac{R_S}{R_S + R_S} \quad v_{ts} = 0.984$$

$$R_{td} := R_p(R_D, R_L) \quad R_{td} = 6.667 \cdot 10^3$$

$$G_{ms} := \frac{1}{r'_s + R_{ts}} \cdot \frac{r_0 + r'_s}{r_0 + R_p(r'_s, R_{ts})}$$

$$i_{dsc} := -G_{ms} \cdot v_{ts} \qquad i_{dsc} = -2.637 \cdot 10^{-3}$$

$$v_o := -i_{dsc} \cdot R_p(r_{id}, R_{td}) \qquad v_o = 15.873 \qquad \text{This is the voltage gain.}$$

$$r_{out} := R_p(R_D, r_{id}) \qquad r_{out} = 8.61 \cdot 10^3$$

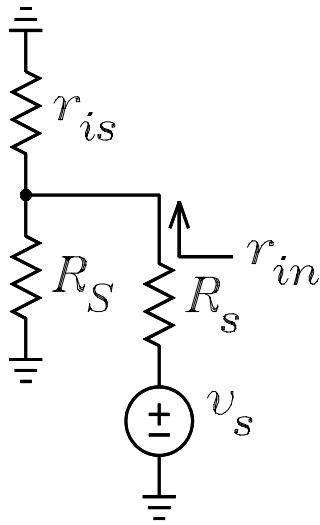

$$r_{is} := r'_s \cdot \frac{r_0 + R_{td}}{r_0 + r'_s} \qquad r_{is} = 363.932$$

$$r_{in} := R_p(r_{is}, R_S) \qquad r_{in} = 324.56$$