

Contents

2	The Junction Diode	3
1.1	Introduction	3
1.2	Terminal Characteristics of the Diode	3
1.2.1	Diode Volt-Ampere Characteristics	4
1.3	Temperature Dependence of the Diode $i - v$ Characteristics	5
1.3.1	Temperature Dependence of v	5
1.3.2	Temperature Dependence of I_S	6
1.4	Graphical Solution of Diode Circuits	7
1.5	A Piecewise Linear Diode Model	9
1.6	The Diode Small-Signal Resistance	11
1.6.1	Small-Signal Current and Voltage	11
1.6.2	Small-Signal Resistance	13
1.6.3	Graphical Interpretation	13
1.6.4	Linear Diode Models	13
1.6.5	Small-Signal Diode Model	15
1.7	Breakdown Characteristics	17
1.7.1	Zener Breakdown	17
1.7.2	Avalanche Breakdown	18
1.7.3	Volt-Ampere Characteristics	18
1.7.4	Model Equation for the $i - v$ Characteristics	18
1.7.5	Circuit Symbol for the Zener Diode	19
1.7.6	Power Dissipation	20
1.7.7	Linear Circuit Model	20
1.7.8	Temperature Effects	22
1.8	Charge Storage in the Diode	22
1.8.1	Charge Storage Mechanisms	22
1.8.2	The Junction Charge	23
1.8.3	Junction Grading	23
1.8.4	The Diffusion Charge	23
1.8.5	Charge Model of the Diode	24
1.8.6	Effect of Diffusion Charge on Switching Speed	24
1.9	The Diode Small-Signal Capacitance	25
1.9.1	Small-Signal Junction Charge	25
1.9.2	Junction Capacitance	26
1.9.3	Small-Signal Diffusion Charge	26

1.9.4	Diffusion Capacitance	27
1.9.5	Diode Small-Signal Model	27
1.9.6	Varactor Diode	27
1.10	The Schottky Barrier Diode	28
1.11	The SPICE Diode Model	30
1.12	Power Supply Rectifier Circuits	30
1.12.1	Half-Wave Rectifier	30
1.12.2	Full-Wave Rectifier	34
1.12.3	Full-Wave Rectifier without a Center-Tapped Transformer	37
1.13	Diode Clipper Circuits	37
1.13.1	Peak Clipper	37
1.13.2	Center Clipper	40

Chapter 2

The Junction Diode

1.1 Introduction

The junction diode is the most fundamental active element of solid-state electronics. The diode is a two terminal device which exhibits the characteristics of an electronic *rectifier*. That is, it is a device which passes a current in only one direction when a voltage is applied to its terminals. Diodes are used in power supply circuits where an ac voltage is converted into a dc voltage. They are also used in analog signal processing circuits. For example, they are used as detector elements in radio, television, and communications receivers. Not only is the diode an important element in its own right, but also it is a basic building block in the fabrication of other devices. For example, the bipolar junction transistor (BJT) is fabricated with at least two internal diode junctions. Similarly, the field effect transistor (FET) is also fabricated with internal diode junctions. For this reason, an understanding of the operation of the diode is fundamental to the understanding of the BJT and the FET.

1.2 Terminal Characteristics of the Diode

The junction diode is fabricated as a p-n junction that has two ohmic contacts, one which contacts the n-type side and the other which contacts the p-type side. This is illustrated in Fig. 1.1a. The terminal on the n-type side is called the *cathode*. The terminal on the p-type side is called the *anode*. In the figure, the reference directions for the voltage v and current i correspond to the polarities for a forward biased junction. The circuit symbol for the diode is shown in Fig. 1.1(b). The arrow in the symbol indicates the direction of forward bias current flow through the junction. It always points from the p-type side to the n-type side, i.e. from anode to cathode.

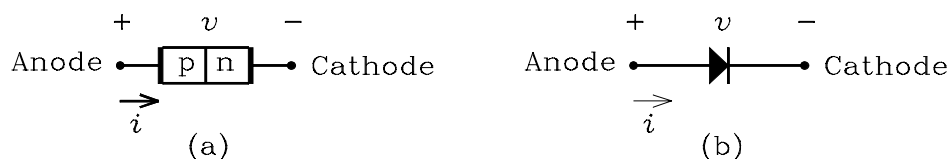

Figure 1.1: (a) p-n junction representation of a diode. (b) Diode circuit symbol.

1.2.1 Diode Volt-Ampere Characteristics

The currents which flow in a p-n junction when it is both reverse biased and forward biased are discussed in the preceding chapter. It is shown that the current is a function of the external voltage applied to the junction. The theoretical equation for the current can be shown to be

$$i = I_S \left[\exp \left(\frac{v}{\eta V_T} \right) - 1 \right] \quad (1.1)$$

where I_S is the *saturation current*, η is the *emission coefficient* or *ideality factor*, and $V_T = kT/q$ is the thermal voltage. At $T = 300\text{ K}$, the thermal voltage has the value $V_T = 0.0259\text{ V}$.

The saturation current is a function of temperature given by

$$I_S = KT^{3/\eta} \exp \left(-\frac{V_G}{\eta V_T} \right) = KT^{3/\eta} \exp \left(-\frac{qV_G}{\eta kT} \right) \quad (1.2)$$

where K is a constant, T is the absolute temperature, V_G is the semiconductor bandgap voltage, and V_T is the thermal voltage. The constant K is directly proportional to the cross-sectional area of the junction. Because the diode current is proportional to I_S , it follows that the current is also proportional to the junction area. The saturation current is very small and has the typical value $I_S \simeq 10^{-9}\text{ A}$ for a discrete low-power silicon diode that is not fabricated as a part of an integrated circuit. The typical value for a low-power integrated circuit silicon diode is $I_S \simeq 10^{-14}\text{ A}$.

The *emission coefficient* or *ideality factor* η accounts for the effect of recombinations of holes with free electrons in the depletion region of the diode. (The symbol n is often used for the emission coefficient. We use η here to prevent confusion with the electron concentration n .) These recombinations have the effect of reducing the diode current. If the number of recombinations is negligible, the emission coefficient has the value $\eta \simeq 1$. If the number of recombinations cannot be neglected, then $1 < \eta \leq 2$. For a given diode, the value of η is a function of the semiconductor material and the doping levels in the n-type and p-type sides. Discrete silicon diodes that are not fabricated as part of an integrated circuit have the value $\eta \simeq 2$. Silicon diodes that are fabricated as part of an integrated circuit have the value $\eta \simeq 1$.

Figure 1.2 shows a plot of the current i versus the voltage v for a typical silicon diode. The plot is called the diode $i - v$ characteristics. The diode is reverse biased for $v < 0$. In this region, the current is equal to the saturation current I_S . Because this is so small, the reverse bias current appears to be zero in the figure. The diode is forward biased for $v > 0$. As the voltage is increased, the current does not appear to begin increasing until the voltage is approximately 0.5 V . This value is called the *cutin voltage* or *threshold voltage*. We denote this by the symbol V_γ . For $v > V_\gamma$, the current increases rapidly with voltage. A typical voltage across a silicon diode biased above threshold is 0.6 V to 0.7 V . This is illustrated in Fig. 1.2.

The curve in Fig. 1.2 is the plot of an exponential equation that increases so rapidly that it appears to approach an almost vertical line at $v \simeq 0.7\text{ V}$. Let us investigate the change in voltage with current in this region. For $i \gg I_S$, Eq. (1.1) can be approximated by

$$i = I_S \exp \left(\frac{v}{\eta V_T} \right) \quad (1.3)$$

Let two points on the curve have the coordinates (v_1, i_1) and (v_2, i_2) . It follows that

$$\frac{i_2}{i_1} = \exp \left(\frac{v_2 - v_1}{\eta V_T} \right) \quad (1.4)$$

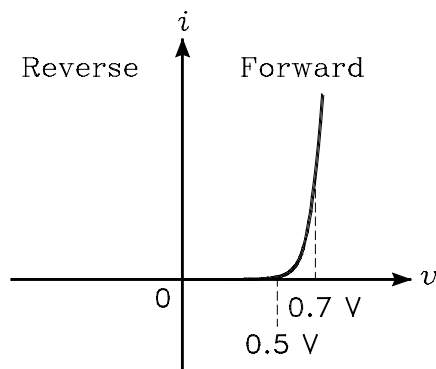

Figure 1.2: $i-v$ characteristics for a typical silicon diode.

This equation can be solved for $\Delta v = v_2 - v_1$ to obtain

$$\Delta v = v_2 - v_1 = \eta V_T \ln \left(\frac{i_2}{i_1} \right) \quad (1.5)$$

For an example calculation, let $i_2 = 10i_1$. At room temperature, we have $\Delta v = \eta V_T \ln(10) \simeq 0.06\eta$. It follows that the change in voltage necessary to change the current by a decade is $\Delta v \simeq 0.06$ V for $\eta = 1$ and $\Delta v = 0.12$ V for $\eta = 2$. Thus a small change in voltage causes a large change in current.

Example 1 A silicon diode with $\eta = 2$ has a current of 1 mA when the voltage is 0.7 V. At room temperature, calculate (a) the saturation current and (b) the range of voltages across the diode if the current varies from 0.1 mA to 10 mA.

Solution. (a) Eq. (1.3) can be used to solve for the saturation current as follows:

$$I_S = i \times \exp \left(\frac{-v}{\eta V_T} \right) = 0.001 \times \exp \left(\frac{-0.7}{2 \times 0.0259} \right) = 1.35 \times 10^{-9} \text{ A}$$

(b) Let v_1 be the voltage for $i = 0.1$ mA and v_2 be the voltage for $i = 10$ mA. Eq. (1.5) gives $\Delta v = 0.12$ V for a decade change in the current. The current 0.1 mA is one decade lower than 1 mA. The current 10 mA is one decade higher than 1 mA. It follows that v_1 and v_2 are given by

$$v_1 = 0.7 - 0.12 = 0.58 \text{ V}$$

$$v_2 = 0.7 + 0.12 = 0.82 \text{ V}$$

1.3 Temperature Dependence of the Diode $i-v$ Characteristics

1.3.1 Temperature Dependence of v

Not only is the diode current a function of the voltage across it, but also it is a function of the temperature. In this section, we solve for the change in diode voltage divided by the change in

temperature for a constant current. Eq. (1.1) can be solved for the diode voltage to obtain

$$v = \eta V_T \ln \left(\frac{i}{I_S} + 1 \right) \simeq \eta V_T \ln \left(\frac{i}{I_S} \right) \quad (1.6)$$

where we assume that $i \gg I_S$. Both V_T and I_S in this equation are functions of temperature. If i is held constant, it follows by the chain rule for derivatives that dv/dT is given by

$$\begin{aligned} \frac{dv}{dT} &= \eta \frac{dV_T}{dT} \ln \left(\frac{i}{I_S} \right) + \eta V_T \left(\frac{i}{I_S} \right)^{-1} \left(\frac{-i}{I_S^2} \right) \frac{dI_S}{dT} \\ &= \eta \frac{dV_T}{dT} \ln \left(\frac{i}{I_S} \right) - \eta V_T \frac{1}{I_S} \frac{dI_S}{dT} \end{aligned} \quad (1.7)$$

To evaluate dv/dT , we must first solve for dV_T/dT and dI_S/dT . Because $V_T = kT/q$, it follows $dV_T/dT = k/q$. Using Eqs. (1.2) and the chain rule for derivatives, we can solve for dI_S/dT as follows:

$$\begin{aligned} \frac{dI_S}{dT} &= \frac{d}{dT} \left[KT^{3/\eta} \exp \left(-\frac{qV_G}{\eta kT} \right) \right] \\ &= \frac{3}{\eta} KT^{(3/\eta)-1} \exp \left(-\frac{qV_G}{\eta kT} \right) + KT^{3/\eta} \exp \left(-\frac{qV_G}{\eta kT} \right) \frac{qV_G}{\eta kT^2} \\ &= I_S \left(\frac{3}{\eta T} + \frac{V_G}{\eta T V_T} \right) \end{aligned} \quad (1.8)$$

It follows that Eq. (1.7) reduces to

$$\begin{aligned} \frac{dv}{dT} &= \eta \frac{k}{q} \ln \left(\frac{i}{I_S} \right) - \eta V_T \left(\frac{3}{\eta T} + \frac{V_G}{\eta T V_T} \right) \\ &= \frac{v - (3V_T + V_G)}{T} \end{aligned} \quad (1.9)$$

where Eq. (1.6) has been used in the simplification.

For a silicon diode at room temperature, we have $V_T = 0.0259$ V, $V_G = 1.11$ V, and $T = 300$ K. For a nominal diode voltage $v = 0.7$ V, Eq. (1.9) can be evaluated for dv/dT to obtain

$$\frac{dv}{dT} \simeq -1.96 \text{ mV}/^\circ\text{C} \quad (1.10)$$

Thus the voltage across a forward biased silicon diode decreases by about 2 mV for each $^\circ\text{C}$ increase in temperature.

1.3.2 Temperature Dependence of I_S

When a diode is reverse biased, its current is equal to the saturation current I_S , which is a function of temperature. To solve for the temperature sensitivity of I_S , we can write

$$\frac{d}{dT} [\ln(I_S)] = \frac{1}{I_S} \times \frac{dI_S}{dT} = \frac{3}{\eta T} + \frac{V_G}{\eta T V_T} \quad (1.11)$$

where Eq. (1.8) has been used for dI_S/dT . It follows from this equation that we can write

$$\Delta [\ln(I_S)] \simeq \left(\frac{3}{\eta T} + \frac{V_G}{\eta T V_T} \right) \Delta T \quad (1.12)$$

If I_{S1} is the value of I_S for a temperature T and I_{S2} is the value at temperature $T + \Delta T$, this equation can be solved for the ratio I_{S2}/I_{S1} to obtain

$$\frac{I_{S2}}{I_{S1}} \simeq \exp \left[\left(\frac{3}{\eta T} + \frac{V_G}{\eta T V_T} \right) \Delta T \right] \quad (1.13)$$

Let us assume a silicon diode at room temperature. For $\Delta T = 10^\circ\text{C}$, it follows from this equation that

$$\begin{aligned} \frac{I_{S2}}{I_{S1}} &\simeq 4.62 \text{ for } \eta = 1 \\ &\simeq 2.15 \text{ for } \eta = 2 \end{aligned} \quad (1.14)$$

Thus, depending on η , the diode saturation current approximately doubles to quintuples for each 10°C increase in temperature.

For a physical diode that is reverse biased, the current variation with temperature is less than the values predicted by Eq. (1.13). This is because there is a component of reverse bias current that flows around the junction rather than through it. This current is called a *surface leakage current*. It varies with temperature at a slower rate than the reverse-bias current through the junction. A rule of thumb that is often used for discrete silicon diodes is to assume that the reverse-bias current approximately doubles for each 10°C increase in temperature.

1.4 Graphical Solution of Diode Circuits

The diode $i-v$ characteristic is not linear. Therefore, the methods of linear circuit analysis cannot be used to solve circuits containing diodes without the aid of linearized models. Such a model is discussed in the following. In this section, a graphical technique is described that can be used to solve for the diode current and voltage. The method requires the circuit external to the diode to be represented by a Thévenin equivalent circuit.

Figure 1.3a shows a diode connected to a dc voltage source having an open-circuit voltage V_S and an output resistance R_S . The source represents the Thévenin equivalent circuit seen by the diode. For this circuit, we can write

$$I_D = \frac{V_S - V_D}{R_S} \quad (1.15)$$

Fig. 1.3(b) shows the graph of this equation and the graph of the diode current versus voltage. The graph of Eq. (1.15) is called a *load line*. The intersection of the load line with the diode curve gives the diode current I_D and voltage V_D . The intersection is called the *Q-point*, where the Q denotes *quiescent*. The word quiescent means "quiet, still, or inactive" and is used in this context to imply a dc solution, i.e. a solution that does not include a time varying ac signal.

The analysis of diode circuits by graphical techniques gives a great deal of insight into a problem. However, the solution requires accurate plots of the curves which can be a tedious process. A technique that is useful in many cases is to use the graphical method to first obtain an approximate solution. Then the circuit equations are used to iteratively seek the a more precise solution. This is illustrated in the following example.

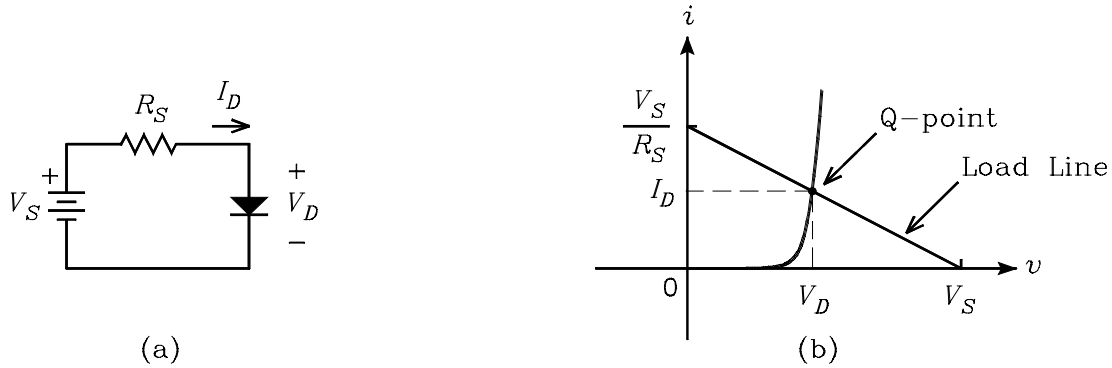

Figure 1.3: (a) Diode circuit. (b) Plot of the load line on the diode $i - v$ characteristics.

Example 2 For the circuit in Fig. 1.4, it is given that $V_1 = 12\text{ V}$, $R_1 = R_2 = R_3 = 1\text{ k}\Omega$. The diode has the model parameters $I_S = 10^{-9}\text{ A}$ and $\eta = 2$. (a) Solve for the Thévenin equivalent circuit seen by the diode. (b) Plot the load line on the diode $i - v$ characteristics and obtain an approximate value for the diode voltage and current. (c) Use an iterative technique to solve for more precise values for the current and voltage.

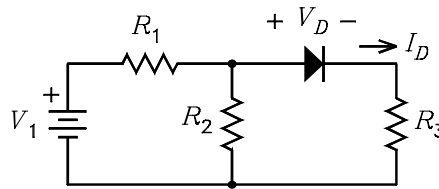

Figure 1.4: Diode circuit.

Solution. (a) The diode sees a Thévenin equivalent source with the open-circuit voltage V_S and output resistance R_S given by

$$V_S = V_1 \frac{R_2}{R_1 + R_2} = 12 \frac{1k}{1k + 1k} = 6\text{ V}$$

$$R_S = R_1 \parallel R_2 + R_3 = 1k \parallel 1k + 1k = 1.5\text{ k}\Omega$$

(b) From Eq. (1.15), the equation for the load line is

$$I_D = \frac{V_S - V_D}{R_S} = \frac{6 - V_D}{1.5k}$$

The graph of the load line and the diode current versus voltage are shown in Fig. 1.5. From the graph, approximate values for the diode voltage and current are $V_D \simeq 0.8\text{ V}$ and $I_D \simeq 3.5\text{ mA}$. (c) For $V_D = 0.8\text{ V}$, the load line equation gives the current

$$I_D = \frac{6 - 0.8}{1.5k} = 3.47\text{ mA}$$

For $I_D = 3.47 \text{ mA}$, Eq. (1.6) can be used to solve for the voltage to obtain

$$V_D = \eta V_T \ln \left(\frac{I_D}{I_S} + 1 \right) = 0.0518 \ln \left(\frac{3.47 \times 10^{-3}}{10^{-9}} + 1 \right) = 0.780 \text{ V}$$

An additional iteration for I_D and V_D can be calculated as follows:

$$I_D = \frac{6 - 0.78}{1.5k} = 3.48 \text{ mA}$$

$$V_D = 0.0518 \ln \left(\frac{3.48 \times 10^{-3}}{10^{-9}} + 1 \right) = 0.780 \text{ V}$$

Because V_D has not changed from the previous iteration, these values can be assumed to be the solution.

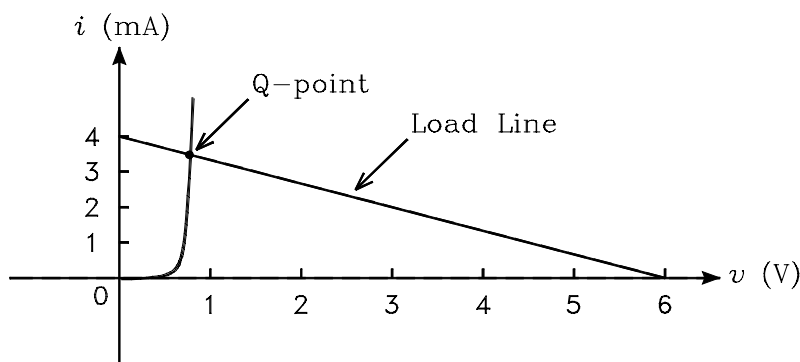

Figure 1.5: Plot of the load line on the diode $i - v$ characteristics.

1.5 A Piecewise Linear Diode Model

The analysis of circuits containing diodes can be simplified by replacing the diode with what is called a *piecewise linear model*. This is a model which approximates the diode $i - v$ characteristics by straight line segments. In each segment, the approximation is linear so that linear circuit analysis can be used to analyze the circuit. To develop the piecewise linear model, we must first introduce the concept of an *ideal diode*. An ideal diode is a diode which has zero current through it when it is reverse biased and zero voltage across it when forward biased. That is, it is an open circuit when reverse biased and a short circuit when forward biased. Fig. 1.6 shows the current versus voltage for the ideal diode. The *break point* in the curve is the point where $v = 0$ and $i = 0$. At this point, the slope is not defined.

Figure 1.7(a) shows the circuit diagram of a piecewise linear model of a diode. The circuit consists of an ideal diode, a resistor, and a dc voltage source. For $v < V_{D0}$, the diode is reverse biased and $i = 0$. For $v \geq V_{D0}$, the diode is forward biased and i is given by

$$i = \frac{v - V_{D0}}{R_D} \quad (1.16)$$

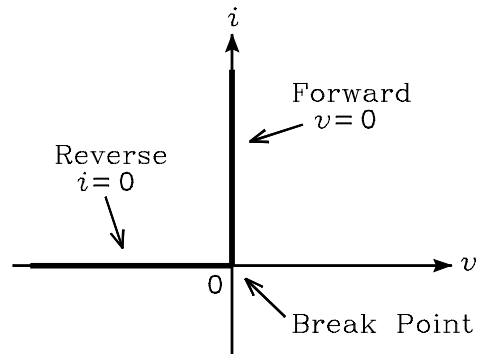

Figure 1.6: $i-v$ characteristics of an ideal diode.

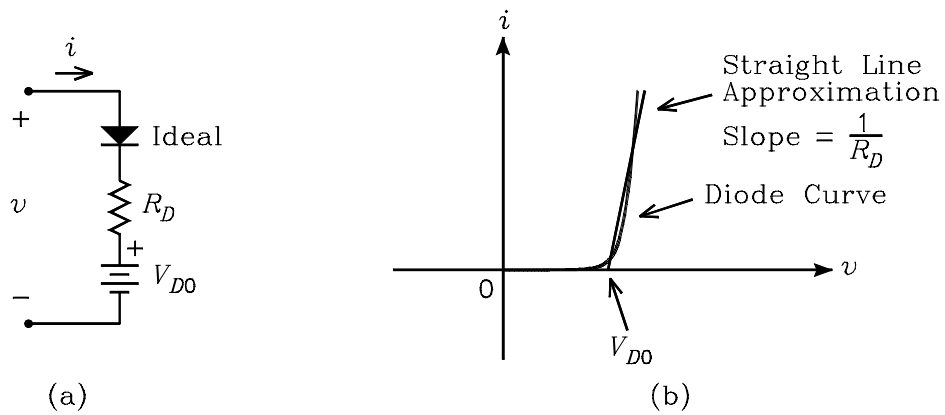

Figure 1.7: (a) Piecewise linear approximation for the diode. (b) $i-v$ characteristic for the piecewise linear approximation.

Figure 1.7(b) shows the graphs of the current versus voltage for a typical silicon diode and for the piecewise linear approximation. The breakpoint in the piecewise linear approximation occurs at $v = V_{D0}$. To the left of this point, the slope of the piecewise linear characteristic is zero. To the right of this point, the slope is $1/R_D$. By proper choice of the breakpoint and the slope, a reasonable approximation to the diode $i - v$ characteristics can be obtained.

Example 3 (a) Obtain a piecewise linear approximation of the diode in Example 2. The approximation is to match the diode $i - v$ characteristics at the currents $i_1 = 0.5 \text{ mA}$ and $i_2 = 5 \text{ mA}$. (b) Use the piecewise linear approximation to solve for the diode current in Example 2.

Solution. (a) Let Δv be the change in voltage across the diode between the two currents. By Eq. (1.5), this is given by

$$\Delta v = \eta V_T \ln \left(\frac{i_2}{i_1} \right) = 0.0518 \ln \left(\frac{5m}{0.5m} \right) = 0.119 \text{ V}$$

R_D is the reciprocal of the slope of the straight line approximation for the current versus voltage. It follows that R_D is given by

$$R_D = \frac{\Delta v}{\Delta i} = \frac{0.119}{5m - 0.5m} = 26.4 \Omega$$

For $i = i_2 = 5 \text{ mA}$, Eq. (1.6) can be used to solve for the diode voltage v_2 as follows:

$$v_2 = \eta V_T \ln \left(\frac{i_2}{I_S} + 1 \right) = 2 \times 0.0259 \ln \left(\frac{5 \times 10^{-3}}{10^{-9}} + 1 \right) = 0.799 \text{ V}$$

It follows from Eq. (1.16) that V_{D0} is given by

$$V_{D0} = v_2 - i_2 R_D = 0.799 - 5m \times 26.4 = 0.667 \text{ V}$$

(b) The equivalent circuit is shown in Fig. 1.8, where V_S and R_S are calculated in Example 2. Because the diode is forward biased, the voltage across the ideal diode is zero. The diode current is given by

$$I_D = \frac{V_S - V_{D0}}{R_S + R_D} = \frac{6 - 0.667}{1.5k + 24.6} = 3.50 \text{ mA}$$

The voltage across the diode is given by

$$V_D = I_D R_D + V_{D0} = 3.5m \times 24.6 + 0.667 = 0.753 \text{ V}$$

1.6 The Diode Small-Signal Resistance

1.6.1 Small-Signal Current and Voltage

When an ac signal is applied to a circuit containing a diode, the current through the diode will undergo a change from its dc or quiescent value. If the change is small, the circuit can be analyzed with linear methods by linearizing the diode equation about its quiescent operating point. Such an analysis is called a *small-signal analysis*. To illustrate this, consider the circuit shown in Fig.

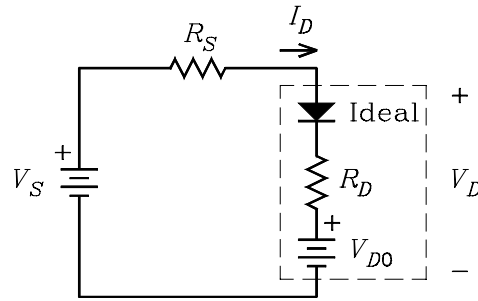

Figure 1.8: Equivalent circuit for calculating the diode current and voltage.

1.9. The diode has two series voltage sources connected to it – a dc source with voltage V_D and an ac source with voltage v_d . We assume that v_d is small enough so that its effect can be analyzed using a small-signal analysis. The current through the diode has two components – a dc component I_D and an ac component i_d . Let the total instantaneous current be denoted by i_D and the total instantaneous voltage be denoted by v_D . These are given by

$$i_D = I_D + i_d \quad (1.17)$$

$$v_D = V_D + v_d \quad (1.18)$$

By Eq. (1.1), I_D is related to V_D by

$$I_D = I_S \left[\exp \left(\frac{V_D}{\eta V_T} \right) - 1 \right] \quad (1.19)$$

We seek a linear relationship between i_d and v_d .

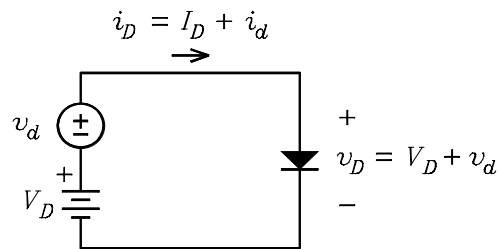

Figure 1.9: Circuit that illustrates the diode small-signal analysis.

If v_d is small, a first-order Taylor series expansion at the point (V_D, I_D) on the diode $i - v$ characteristics can be used to write

$$i_D = I_D + i_d \simeq I_D + \frac{dI_D}{dV_D} \times v_d \quad (1.20)$$

It follows that the small-signal components i_d and v_d are related by the equation

$$i_d \simeq \frac{dI_D}{dV_D} \times v_d \quad (1.21)$$

Eq. (1.1) can be used to evaluate the derivative to obtain

$$i_d \simeq \frac{I_S}{\eta V_T} e^{V_D/\eta V_T} v_d = \frac{I_D + I_S}{\eta V_T} v_d \quad (1.22)$$

This approximation is strictly valid only if $|v_d| \ll 2\eta V_T$. It can be shown that the magnitude of the error in the approximation is less than 10% for $-0.39 \leq v_d/\eta V_T \leq 0.53$.

1.6.2 Small-Signal Resistance

The diode *small-signal resistance* is defined as the ratio of the small-signal voltage v_d to the small-signal current i_d . We denote this by the symbol r_d . From Eq. (1.22), it is given by

$$r_d = \frac{v_d}{i_d} = \frac{\eta V_T}{I_D + I_S} \quad (1.23)$$

The small-signal resistance is sometimes called the *incremental resistance*. That is, it represents the ratio of an increment in voltage to an increment in current. When the diode is forward biased, $I_D \gg I_S$ so that r_d can often be approximated by

$$r_d \simeq \frac{\eta V_T}{I_D} \quad (1.24)$$

1.6.3 Graphical Interpretation

Figure 1.10 shows a plot of the total diode current i_D versus total voltage v_D and the plot of a straight line which is tangent to the curve at the point (V_D, I_D) . The slope of the tangent line is $1/r_d$. The equation of the tangent line is

$$i_D = I_D + \frac{v_D - V_D}{r_d} \quad (1.25)$$

For small changes about the tangent point, it can be seen from the figure that the tangent line predicts approximately the same changes in i_D and v_D as the diode curve does. The figure also illustrates how an ac voltage waveform can be projected on the tangent line to predict the ac current waveform. The small-signal voltage v_d is plotted versus time on the vertical time axis. Each point on the v_d waveform can be projected on the tangent line approximation to predict the corresponding current. The current is plotted versus time on the horizontal time axis.

1.6.4 Linear Diode Models

Two linear circuit models which have an i_D versus v_D characteristic that is identical to the tangent line in Fig. 1.10 are shown in Figs. 1.11(a) and 1.11(b). The circuit of Fig. 1.11a is a Thévenin model whereas the one in Fig. 1.11(b) is a Norton model. The voltage V_{D0} and the current I_{D0} in the circuits are given by

$$V_{D0} = V_D - I_D r_d \quad (1.26)$$

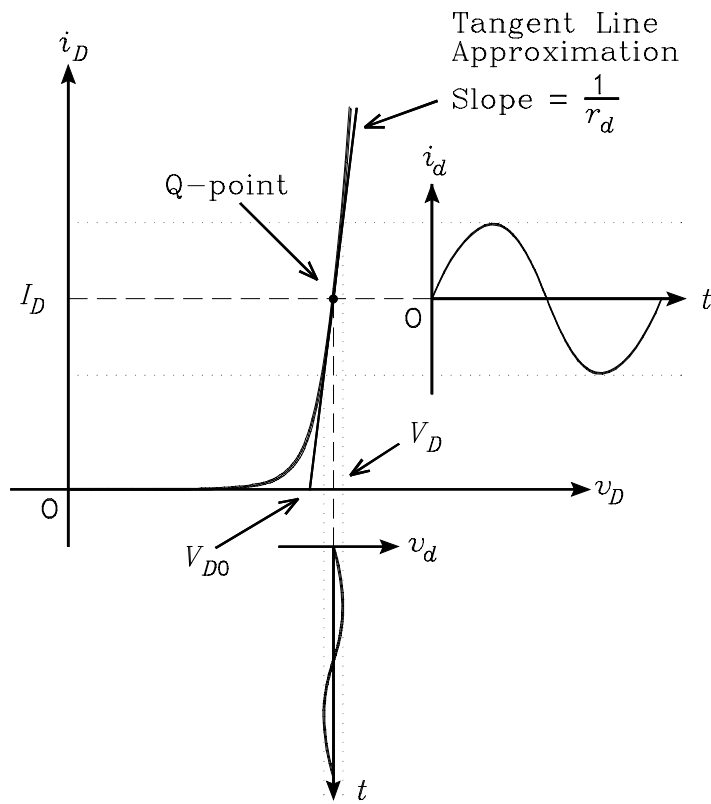

Figure 1.10: Example diode $i - v$ characteristic and a straight line that is tangent to the diode curve at the Q-point.

$$I_{D0} = I_D - \frac{V_D}{r_d} \quad (1.27)$$

Either of the circuits can be used to calculate the total instantaneous diode voltage and current for small changes about an operating point.

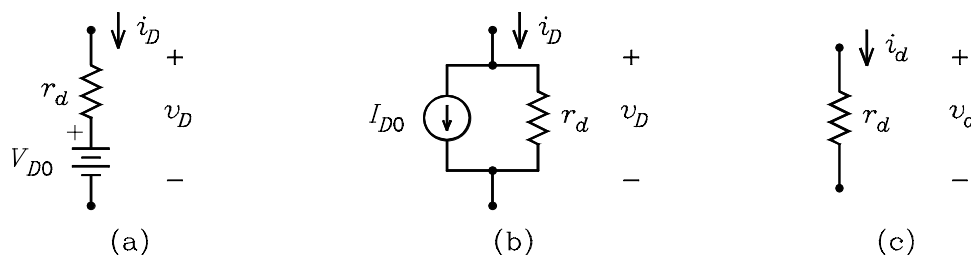

Figure 1.11: (a) Linear Thevenin model of the diode. (b) Linear Norton model of the diode. (c) Small-signal model of the diode.

1.6.5 Small-Signal Diode Model

Because the circuits of Fig. 1.11(a) and 1.11(b) are linear, it follows that linear circuit analysis can be applied to circuits where they are used to model the diode. In particular, the principle of superposition can be applied to circuits in which the models are used. Because the sources in the models are dc sources, it follows by superposition that the sources can be zeroed when using the models to solve for small-signal changes. When the sources are zeroed, the equivalent circuit of Fig. 1.11(c) is obtained. Thus the diode can be reduced to a single resistor for small-signal calculations.

Example 4 At room temperature, the diode in Fig. 1.12 has the model parameters $I_S = 10^{-9}$ A and $\eta = 2$. The dc voltage source has the value $V_1 = 2$ V. The source labeled v_1 puts out a sinusoidal voltage and can be considered to be a small-signal source. (a) For $v_1 = 0$, solve for the value of R_1 which biases the diode at $I_D = 2$ mA. (b) If $v_1 = 0.5 \sin(\omega t)$ V, solve for the ac and the total instantaneous diode current and voltage. Verify that the diode small-signal voltage is in the range such that the error in the small-signal approximation is less than 10%.

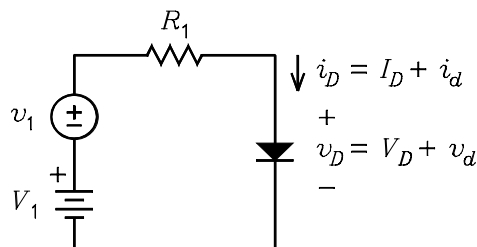

Figure 1.12: Circuit for Example 4.

Solution. (a) for $v_1 = 0$, Eq. (1.6) can be used to solve for the quiescent diode voltage at $I_D = 2\text{ mA}$ to obtain

$$V_D = \eta V_T \ln \left(\frac{I_D}{I_S} + 1 \right) = 2 \times 0.0259 \times \ln \left(\frac{0.002}{10^{-9}} + 1 \right) = 0.752\text{ V}$$

The resistor R_1 is given by

$$R_1 = \frac{V_1 - V_D}{I_D} = \frac{2 - 0.752}{2\text{ m}} = 624\ \Omega$$

(b) The diode small-signal resistance can be calculated from Eq. (1.24) to obtain

$$r_d \simeq \frac{\eta V_T}{I_D} = \frac{2 \times 0.0259}{2\text{ m}} = 25.9\ \Omega$$

The small-signal diode current and voltage are given by

$$i_d = \frac{v_1}{R_1 + r_d} = \frac{0.5}{624 + 25.9} \sin(\omega t) = 0.769 \sin(\omega t)\text{ mA}$$

$$v_d = i_d r_d = 0.769\text{ m} \times 25.9 \sin(\omega t) = 19.9 \sin(\omega t)\text{ mV}$$

The total instantaneous current and voltage are given by

$$i_D = I_D + i_d = 2 + 0.769 \sin(\omega t)\text{ mA}$$

$$v_D = V_D + v_d = 752 + 19.9 \sin(\omega t)\text{ mV}$$

From the discussion following Eq. (1.22), the error in i_d is less than 10% if $-0.39 \leq v_d/\eta V_T \leq 0.53$ or $-20.2\text{ mV} \leq v_d \leq 27.5\text{ mV}$. This inequality is satisfied by v_d .

Example 5 Figure 1.13(a) shows a diode attenuator circuit. The input voltage v_i is a small-signal differential voltage represented by two series sources with the common terminal grounded. The current I_Q is a dc control current. Solve for the small-signal gain v_o/v_i . Assume the diodes are identical, $n = 2$, and $V_T = 0.025\text{ V}$.

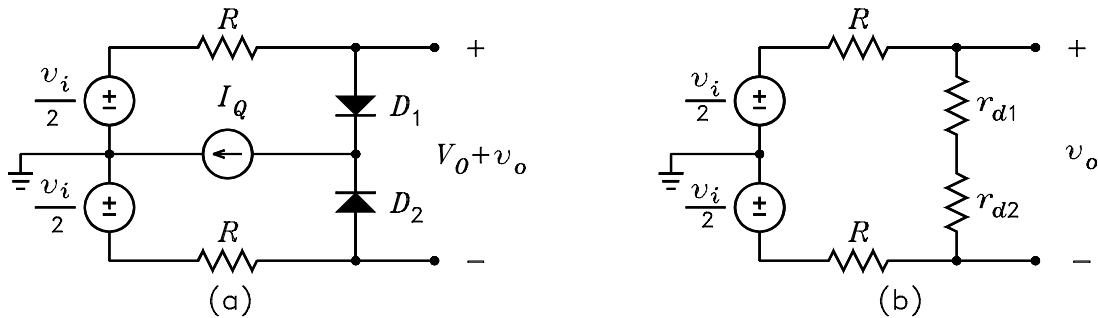

Figure 1.13: (a) Diode attenuator circuit. (b) Small-signal circuit for calculating v_o .

Solution. For the dc solution, we set $v_i = 0$. In this case, $v_o = 0$. For identical diodes, the current I_Q splits equally between the two. It follows the dc voltages across the diodes cancel in calculating V_O so that $V_O = 0$. The small-signal resistance of each diode is $r_{d1} = r_{d2} = 2nV_T/I_Q = 0.1/I_Q$. The small-signal circuit is shown in Fig. 1.13(b). The current I_Q does not appear in this circuit because it is a dc source which becomes an open circuit when zeroed. It follows by voltage division that

$$\frac{v_o}{v_i} = \frac{r_{d1} + r_{d2}}{2R + r_{d1} + r_{d2}} = \frac{2 \times 0.1/I_Q}{2R + 2 \times 0.1/I_Q} = \frac{1}{1 + 10I_Q R}$$

Thus the small-signal gain of the circuit can be varied by varying the dc current I_Q . A typical plot of the gain versus current is shown in Fig. 1.14.

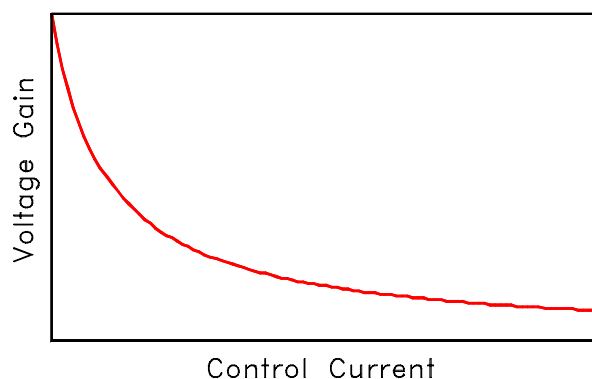

Figure 1.14: Plot of voltage gain versus control current.

1.7 Breakdown Characteristics

The current in a reverse-biased diode is so small that it is often approximated by zero in calculations. However, if the reverse-bias voltage is large enough, the diode will break down and a large current will flow. There are two mechanisms which are responsible for this behavior. If the diode breaks down for a reverse-bias voltage of less than about six volts, the mechanism is said to be *Zener breakdown*. If the diode breaks down for a reverse-bias voltage of greater than about six volts, the mechanism is said to be *avalanche breakdown*. In the fabrication of a diode, the parameters can be controlled to vary the particular voltage at which breakdown occurs. Diodes which are fabricated specifically to be operated in the breakdown region are called *Zener diodes*. They are called this even if the breakdown mechanism is due to the avalanche effect.

1.7.1 Zener Breakdown

Voltage breakdown in a reverse-biased diode is related to the electric field in the depletion region. The uncovered charges on each side of the junction can be thought of as the charges on the plates of a parallel-plate capacitor, where the voltage on the capacitor is the voltage across the junction. If the diode is heavily doped, the width of the depletion region is very small. Because the electric field in a capacitor is equal to the voltage divided by the distance between the plates, the small

width of the depletion region makes the electric field high. If the electric field exceeds about 2×10^7 V/m, the force exerted on the valence electrons will be strong enough to pull electrons out of their parent atoms. When this happens, hole-electron pairs are created in the depletion region and a large reverse-bias current flows across the junction. If the formation of the hole-electron pairs is continuous, the diode is said to be in *Zener breakdown*. This occurs in diodes which are doped so that they break down below about six volts. The heavier the doping, the lower the breakdown voltage. Zener breakdown is sometimes referred to as *field emission* effects or *tunneling*. The latter name comes from a quantum mechanical description of the phenomenon.

1.7.2 Avalanche Breakdown

In a reverse-biased diode which is not heavily doped, the depletion region is wide enough so that a different breakdown phenomenon occurs before the voltage can be made large enough to cause field emission. This mechanism is called avalanche breakdown. To see how it arises, consider a thermally generated hole-electron pair in the depletion region of a reverse-biased diode. The electric field across the junction causes the hole and the electron to be accelerated in opposite directions. If either one collides with a bound atom with sufficient velocity, another hole-electron pair will be created by the collision. When this effect becomes self sustaining, the diode is said to be in avalanche breakdown. It occurs in diodes which are doped so that they break down above about six volts. The lighter the doping, the higher the breakdown voltage.

1.7.3 Volt-Ampere Characteristics

Figure 1.15 shows the plot of the $i-v$ characteristics for a typical Zener diode. In the reverse-biased region, the Zener knee on the curve is the point at which the diode appears to break down. To the left of the knee, the reverse current increases rapidly with reverse-bias voltage. Zener diodes are specified by giving the *Zener breakdown voltage* V_Z , the *Zener breakdown current* I_Z at which V_Z is specified, and the *Zener small-signal resistance* r_z at that current. The small-signal resistance is the reciprocal of the slope of the $i-v$ characteristics at the point $(-V_Z, -I_Z)$. An ideal Zener diode would have $r_z = 0$. This would correspond to an $i-v$ curve which is a vertical line in the breakdown region. For physical diodes, r_z is a function of both V_Z and I_Z . It exhibits a minimum on the order of several ohms for diodes having a V_Z in the range of 6 to 10 V. For V_Z outside this range, it may be of the order of several hundred ohms, particularly for small currents, e.g. $I_Z \simeq 1$ mA.

1.7.4 Model Equation for the $i-v$ Characteristics

To approximately model breakdown effects, the equation for the diode $i-v$ characteristics given by Eq. (1.1) is modified by adding a term that represents the breakdown current. The modified equation is

$$i = I_S \left[\exp \left(\frac{v}{\eta V_T} \right) - 1 \right] - I_Z \exp \left(-\frac{v + V_Z}{\eta_z V_T} \right) \quad (1.28)$$

where η_z is the *Zener breakdown ideality factor*. For physical diodes, $I_Z \gg I_S$ so that this equation predicts that $i \simeq -I_Z$ for $v = -V_Z$. The small-signal resistance at any point on the characteristics is given by the reciprocal of di/dv at that point. At the point $(-V_Z, -I_Z)$ the small-signal resistance

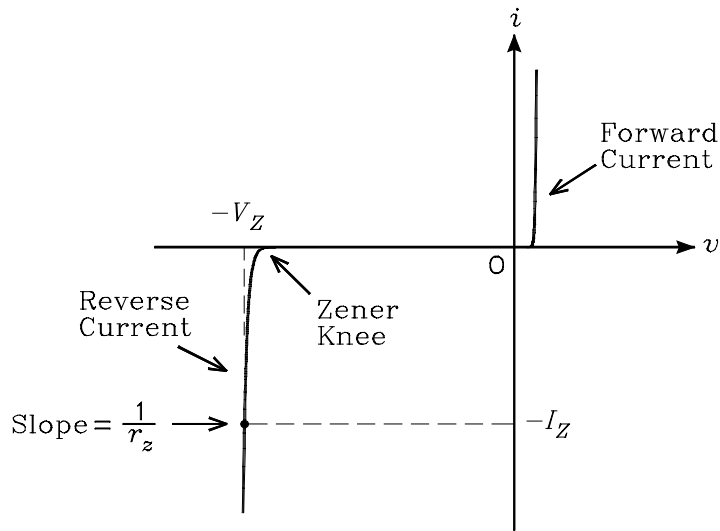

Figure 1.15: $i - v$ characteristics of a diode showing the reverse breakdown region.

is given by

$$r_z = \frac{\eta_z V_T}{I_Z} \tag{1.29}$$

where it is assumed that $I_S \ll I_Z$.

1.7.5 Circuit Symbol for the Zener Diode

Figure 1.16 shows the circuit symbol for the Zener diode. Because the diode is reverse biased in normal applications, the current and voltage are labeled backward compared to the conventional directions. Thus positive current flows into the cathode and the cathode voltage is positive with respect to the anode voltage.

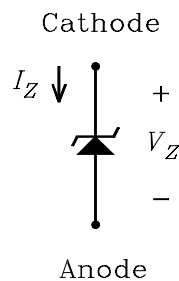

Figure 1.16: Circuit symbol for the Zener diode.

1.7.6 Power Dissipation

The power dissipated by a Zener diode is given by the product of its voltage and its current. If the reverse current becomes too large, the power can exceed the maximum power dissipation and the diode can fail. We denote the maximum power dissipation by P_D . A specification of P_D can be used to calculate the maximum reverse current before the power dissipation is exceeded. This maximum current is given by

$$I_{\text{MAX}} = \frac{P_D}{V_Z} \quad (1.30)$$

1.7.7 Linear Circuit Model

Figure 1.17(a) shows a plot of the $i - v$ characteristics of a Zener diode in the reverse-biased region where the reference directions for the current and voltage have been reversed compared to those in Fig. 1.15. We refer to such a plot as the *reverse* $i - v$ characteristics. The horizontal axis in the figure has been broken and expanded to the right of the break to better show the reverse characteristics in the region of the Zener knee. The figure shows the plot of the tangent line at the point (V_Z, I_Z) . The slope of the line is $1/r_z$. The equation for the tangent line is

$$i = \frac{v - V_{Z0}}{r_z} + I_Z = \frac{v - V_{Z0}}{r_z} \quad (1.31)$$

where V_{Z0} is the voltage at which the tangent line intersects the horizontal axis. This is given by

$$V_{Z0} = V_Z - I_Z r_z \quad (1.32)$$

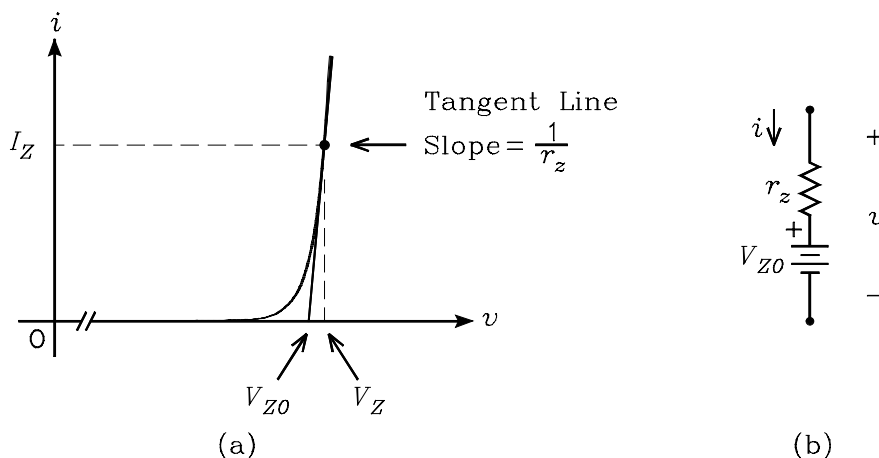

Figure 1.17: (a) Plot of the Zener diode reverse $i - v$ characteristics. (b) Linear circuit which approximates the breakdown characteristics.

A linear circuit which has the $i - v$ characteristics given by the tangent line is shown in Fig. 1.17(b). When $i = I_Z$, the voltage across this circuit is $v = V_Z$. It follows that the circuit can be used to model the Zener diode when it is biased at or near the point (V_Z, I_Z) on the reverse $i - v$ characteristics. The circuit is useful in predicting changes in the voltage across the diode when the current through it changes.

Example 6 A Zener diode at room temperature ($V_T = 0.0259\text{ V}$) has the specifications $V_Z = 10\text{ V}$, $I_Z = 10\text{ mA}$, and $r_z = 20\Omega$. Calculate (a) the Zener breakdown ideality factor η_z , (b) the voltage V_{Z0} in the linear circuit of Fig. 1.17(a), and (c) the voltage at which the breakdown current is $I_Z/10$.

Solution. (a) Eq. (1.29) can be used to solve for η_z to obtain

$$\eta_z = \frac{I_Z r_z}{V_T} = \frac{10\text{m} \times 20}{25.9\text{m}} = 7.72$$

(b) The voltage V_{Z0} is calculated from Eq. (1.32) to obtain

$$V_{Z0} = V_Z - I_Z r_z = 10 - 10\text{m} \times 20 = 9.8\text{ V}$$

(c) If $I_S \ll I_Z$, Eq. (1.28) can be solved for the voltage at which $i = -1\text{ mA}$ as follows:

$$v = -V_Z - \eta_z V_T \ln\left(\frac{i}{-I_Z}\right) = -10 - 7.72 \times 25.9\text{m} \times \ln(0.1) = -9.54\text{ V}$$

The reverse-bias voltage is the negative of this, i.e. $+9.54\text{ V}$.

Example 7 The Zener diode of Example 6 is used in the circuit of Fig. 1.18(a). It is given that $V_1 = 15\text{ V}$ and $R_2 = 1\text{ k}\Omega$. (a) Calculate the value of R_1 which will bias the diode at (V_Z, I_Z) on its reverse $i - v$ characteristics. (b) If R_2 is decreased so that I_2 increases by 1 mA , calculate the change in voltage across the diode.

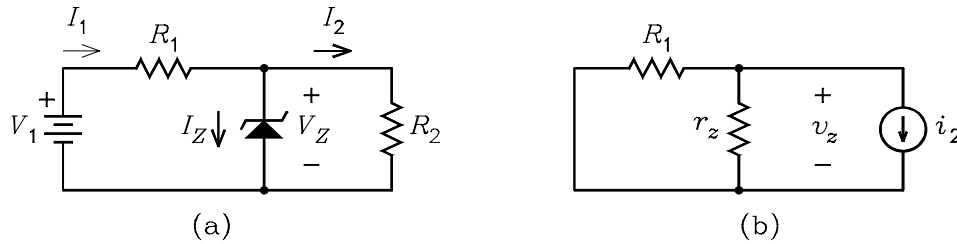

Figure 1.18: (a) Circuit for Example 7. (b) Small-signal circuit for calculating the change in voltage.

Solution. (a) It follows from the figure that

$$I_1 = I_Z + \frac{V_Z}{R_2} = 10\text{m} + \frac{10}{1\text{k}} = 20\text{ mA}$$

Therefore, R_1 is given by

$$R_1 = \frac{V_1 - V_Z}{I_1} = \frac{15 - 10}{20\text{m}} = 250\Omega$$

(b) We denote the change in diode voltage by v_z . To solve for this, we replace the diode with its linear circuit model given in Fig. 1.17(b). Because we are interested only in calculating a change in voltage due to a change in current, the dc voltage sources V_1 and V_{Z0} can be zeroed. The circuit is shown in Fig. 1.18(b), where the change in load current is modeled as a current source. We can write

$$v_z = -i_2(r_z \parallel R_1) = -1\text{m} \times (20 \parallel 250) = -18.5\text{ mV}$$

1.7.8 Temperature Effects

The voltage across a Zener diode that is biased at a constant current in its breakdown region is a function of the temperature. The *temperature coefficient* T_C specifies the percent change in voltage per degree C at room temperature. The coefficient for the Zener breakdown mechanism is negative whereas that for the avalanche mechanism is positive. For diodes that have a V_Z in the range of 4 to 5 V, the temperature coefficient is approximately zero. When the temperature changes over a wide range, the temperature coefficient changes. Therefore, a Zener diode that has a zero temperature coefficient at room temperature will have a non-zero coefficient at a different temperature. A *temperature compensated Zener diode* consists of a Zener diode with a positive temperature coefficient in series with a forward biased diode. The forward biased diode exhibits a negative temperature coefficient so that the series combination can exhibit a zero coefficient. Such diodes can be fabricated to have a zero temperature coefficient over a wide temperature range. Fig. 1.19 shows the circuit diagram of a temperature compensated Zener diode. The voltage across the diode is given by $V_{ZTC} = V_D + V_Z$.

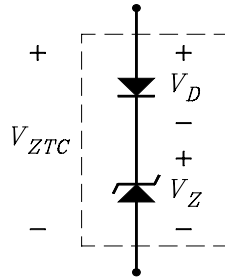

Figure 1.19: Circuit diagram of the temperature compensated Zener diode.

Example 8 The voltage across a forward biased diode is 0.7 V. At room temperature, the voltage changes by $-1.88 \text{ mV}/^\circ\text{C}$. The diode is to be used with a Zener diode to realize a temperature compensated Zener diode having a rated voltage of 10 V. Calculate the required temperature coefficient of the Zener diode at room temperature.

Solution. The Zener diode must have the Zener voltage $V_Z = 10 - 0.7 = 9.3 \text{ V}$. The required temperature coefficient of the diode is calculated as follows:

$$T_C = \frac{-(-1.88\text{m})}{9.3} \times 100\% = 0.020\% \text{ per } ^\circ\text{C}$$

1.8 Charge Storage in the Diode

1.8.1 Charge Storage Mechanisms

There are two components of charge stored in a diode. These are the *junction charge* (also called the *depletion charge*) and the *diffusion charge*. The junction charge consists of the bound uncovered charge in the depletion region. This component of stored charge dominates when the diode is reverse

biased. The diffusion charge consists of the mobile minority charge on each side of the depletion region. This component dominates when the diode is forward biased. If a change in voltage is applied to a diode, the current cannot change unless the stored charge is also changed. Because it takes a finite time to change the charge, the time required to change the state of a diode from conducting to non-conducting, or vice versa, is limited by the charge stored in it.

1.8.2 The Junction Charge

The junction or depletion charge in a p-n junction consists of the bound uncovered charges in the depletion region on each side of the junction that is not neutralized by mobile holes or electrons. On the n-type side of the junction, the uncovered charge is positive. We denote this charge by $+q_J$. On the p-type side, the uncovered charge is negative. We denote this charge by $-q_J$. It can be shown that q_J is given by the integral

$$q_J = \int_0^v \frac{C_{J0} dv'}{(1 - v'/V_B)^m} \quad (1.33)$$

where v is the voltage applied to the diode (which is negative for the reverse biased diode), v' is the variable of integration, C_{J0} is the *zero-bias junction capacitance*, V_B is the junction built-in potential, and m is the *junction grading coefficient*.

1.8.3 Junction Grading

The junction grading coefficient m is a function of the way the diode is doped during its fabrication. If it is fabricated so that there is an abrupt change from acceptor ions on the p-type side to donor ions on the n-type side, the junction is said to be a *step-graded junction*. For this case, the grading coefficient has the value $m = 1/2$. Two other names for the step-graded junction are *alloy junction* and *fusion junction*. If the diode is fabricated so that the change from acceptor ions on the p-type side to donor ions on the n-type side varies linearly with distance from the junction, the junction is said to be a *linearly-graded junction*. In this case, the value of the grading coefficient $m = 1/3$.

1.8.4 The Diffusion Charge

The diffusion process in the diode causes free electrons on the n-type side to diffuse across the junction into the p-type side and holes on the p-type side to diffuse across the junction into the n-type side. On the n-type side, it follows that the mobile diffusion charge is positive. We denote this charge by $+q_D$. On the p-type side, the mobile diffusion charge is negative. We denote this charge by $-q_D$. It can be shown that q_D is given by

$$q_D = \tau_F I \quad (1.34)$$

where τ_F is the *diode transit time* and I is the diode current. Because the current in a reverse biased diode is so small that it is commonly neglected, this equation shows that the diffusion charge is significant only when the diode is forward biased. For any diode, the transit time τ_F is a parameter which must be measured experimentally. Because it is greatly affected by impurities and imperfections in the semiconductor crystal, τ_F can vary over a wide range. Values ranging as high as $1,000 \mu\text{s}$ can occur. However, a typical value may be in the 0.1 ns to 1 ns range for a low-current diode.

1.8.5 Charge Model of the Diode

Figure 1.20 shows the circuit symbol of the diode with parallel capacitors which model the junction charge and the diffusion charge. Because the capacitance is not equal to the stored charge divided by the voltage, it is not possible to assign values to the capacitors. For this reason, only the charge stored on each is labeled in the figure.

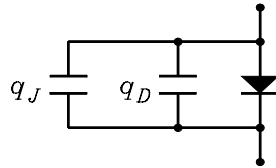

Figure 1.20: Circuit symbol of the diode with capacitors that model the stored charge.

1.8.6 Effect of Diffusion Charge on Switching Speed

The *switching speed* of a diode is the time required to change the state of the diode from conducting to non-conducting. The diffusion charge stored in the diode plays a fundamental role in determining the switching speed. To illustrate this, consider the circuit of Fig. 1.21. Let the voltage source $v_S(t)$ put out a square wave with the peak values $+V_1$ and $-V_1$. The current which flows in the diode is illustrated in Fig. 1.22. When the source goes positive, the diode is forward biased and a peak current I_1 flows. When the source goes negative, the diode cannot cut off until the diffusion charge is depleted. The current falls to a value $-I_1$, stays at that level for a brief period, then linearly increases to zero. The area under the negative pulse represents the diffusion charge that is stored during the time that the diode is forward biased. It follows from Eq. (1.34) that the diode transit time is given by

$$\tau_F = \frac{\text{Area}}{I_1} \quad (1.35)$$

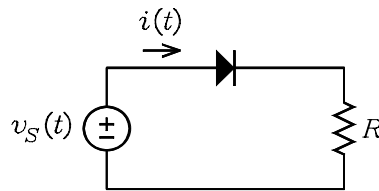

Figure 1.21: Circuit for illustrating the diode switching time.

General purpose power rectifier diodes have a fairly large diffusion charge which makes them unsuitable for applications where fast switching characteristics are desired. However, they are suitable in power-supply applications where the power line frequency is 50 or 60 Hz. Fast-recovery power rectifier diodes are available for higher frequency applications, e.g. as high as 250 kHz.

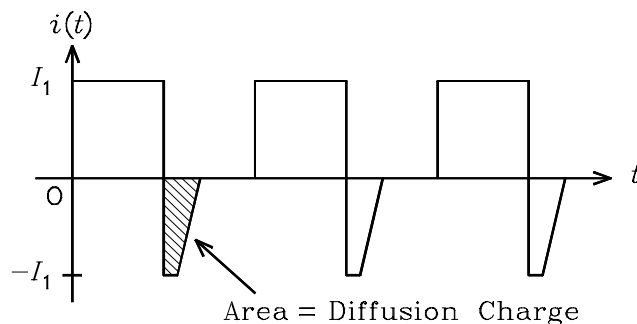

Figure 1.22: Diode current waveform.

The diffusion charge in these diodes is decreased by the addition of what are called *recombination centers* (e.g. atoms of gold) into the semiconductor material. This gives them the fast-recovery characteristics. For low-power applications, fast-switching diodes are available for use in signal detector circuits and in pulse shaping circuits. These diodes have both a low junction charge and a low diffusion charge. However, the maximum current rating is much lower than that of power rectifier diodes.

1.9 The Diode Small-Signal Capacitance

We have seen in the preceding section that there are two components of charge storage in a diode. These are the junction charge and the diffusion charge. As shown in Fig. 1.20, the charges are modeled by adding capacitors in parallel with the diode. The capacitors are non-linear because the charge on them is not proportional to the voltage. However, if the voltage is changed by a small amount, the change in charge on each capacitor is approximately proportional to the change in voltage. Thus a small-signal capacitance can be defined as the ratio of the change in charge to the change in voltage. In this section, we solve for the small-signal capacitance of the diode. This capacitance consists of two parts, one due to the junction charge and the other due to the diffusion charge.

1.9.1 Small-Signal Junction Charge

Let the total instantaneous voltage across the diode be denoted by v_D . Similarly, let the total instantaneous junction charge be denoted by q_J . These can be written

$$v_D = V_D + v_d \quad (1.36)$$

$$q_J = Q_J + q_j \quad (1.37)$$

where V_D and Q_J are dc components and v_d and q_j are small-signal ac components. By Eq. (1.33), Q_J is related to V_D by

$$Q_J = \int_0^{V_D} \frac{C_{J0} dv'}{(1 - v'/V_B)^m} \quad (1.38)$$

We seek a linear relation between q_j and v_d .

If v_d is small, a first-order Taylor series expansion at the point (V_D, Q_J) can be used to write

$$q_J = Q_J + q_j \simeq Q_J + \frac{dQ_J}{dV_D} \times v_d \quad (1.39)$$

It follows that the small-signal components q_j and v_d are related by the equation

$$q_j \simeq \frac{\partial Q_J}{\partial V_D} \times v_d \quad (1.40)$$

Eq. (1.38) can be used to evaluate the derivative to obtain

$$q_j \simeq \frac{C_{J0}}{(1 - V_D/V_B)^m} v_d \quad (1.41)$$

This equation is strictly valid only if $|v_d| \ll |V_D|$.

1.9.2 Junction Capacitance

The diode small-signal *junction capacitance* c_j is defined as the ratio of the small-signal change in the junction charge to the small-signal change in voltage. It is given by

$$c_j = \frac{q_j}{v_d} = \frac{C_{J0}}{(1 - V_D/V_B)^m} \quad (1.42)$$

Although this expression predicts an infinite capacitance if $V_D = V_B$, it is not correct when V_D approaches V_B . An approximation that is often used for $V_D > V_B/2$ is

$$c_j \simeq C_{J0} 2^m \left[1 + m \left(\frac{2V_D}{V_B} - 1 \right) \right] \quad (1.43)$$

This approximation represents a first-order Taylor series expansion to Eq. (1.42) at $V_D = V_B/2$.

1.9.3 Small-Signal Diffusion Charge

Let the total instantaneous diffusion charge be denoted by q_D . This can be written

$$q_D = Q_D + q_d \quad (1.44)$$

where Q_D is the dc component and q_d is the small-signal ac component. By Eqs. (1.1) and (1.34), Q_D is related to V_D by

$$Q_D = \tau_F I_D = \tau_F I_S \left[\exp \left(\frac{V_D}{\eta V_T} \right) - 1 \right] \quad (1.45)$$

We seek a linear relation between q_d and v_d .

If v_d is small, a first-order Taylor series expansion at the point (V_D, Q_D) can be used to write

$$q_D = Q_D + q_d \simeq Q_D + \frac{dQ_D}{dV_D} \times v_d \quad (1.46)$$

It follows that the small-signal components q_d and v_d are related by the equation

$$q_d \simeq \frac{dQ_D}{dV_D} \times v_d \quad (1.47)$$

Eq. (1.45) can be used to evaluate the derivative to obtain

$$q_d \simeq \tau_F \frac{I_D + I_S}{\eta V_T} v_d = \frac{\tau_F}{r_d} v_d \quad (1.48)$$

where r_d is the diode small-signal resistance given by Eq. (1.23). This equation is strictly valid only if $|v_d| \ll 2\eta V_T$.

1.9.4 Diffusion Capacitance

The diode small-signal *diffusion capacitance* c_d is defined as the ratio of the small-signal change in the diffusion charge to the small-signal change in voltage. It is given by

$$c_d = \frac{q_d}{v_d} = \frac{\tau_F}{r_d} \quad (1.49)$$

1.9.5 Diode Small-Signal Model

The low-frequency small-signal model of the diode is developed in Section 1.6. It consists of a resistor r_d given by Eq. (1.23). To model high-frequency effects, the small-signal capacitors c_j and c_d must be added in parallel with r_d . The circuit is shown in Fig. 1.23. When the diode is forward biased, the diffusion capacitance c_d dominates and the junction capacitance c_j is often neglected. When the diode is reverse biased, the junction capacitance c_j dominates and the diffusion capacitance c_d is often neglected.

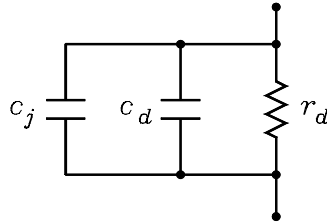

Figure 1.23: Small-signal model of the diode with capacitors which model small-signal changes in the junction and diffusion charges.

1.9.6 Varactor Diode

Although the diode capacitance is a disadvantage in high-speed switching circuits, a diode that is fabricated to be used as a voltage variable capacitor when reverse biased is called a *varactor diode*. Such diodes are used in electronic tuning circuits of communications systems. They are also used in FM modulator circuits where a signal voltage is applied to the diode to change its capacitance which in turn varies the frequency of an oscillator.

Example 9 A junction diode has the parameters $C_{J0} = 20$ pF, $V_B = 1$ V, and $m = 0.5$. Calculate the change in junction capacitance if the reverse bias voltage on the diode is changed from 5 V to 10 V.

Solution. The junction capacitance is given by Eq. (1.42). For $V = -5\text{ V}$, we have $c_j = 20/(1+5)^{0.5}\text{ pF} = 8.2\text{ pF}$. For $V = -10\text{ V}$, we have $c_j = 20/(1+10)^{0.5}\text{ pF} = 6.0\text{ pF}$. Thus the capacitance changes by $8.2 - 6.0 = 2.2\text{ pF}$.

Example 10 Fig. 1.24(a) shows a diode driven by a dc current source I_1 in parallel with a small-signal ac current source i_g . Denote the dc voltage on the diode by V_D and the small-signal ac voltage by v_d . Solve for the small-signal transfer function V_d/I_g as a function of the dc current I_1 . (V_d and I_g , respectively, are the complex phasor notations for v_d and i_g .) Assume that the junction capacitance of the forward biased diode is negligible and that $I_1 \gg I_S$, where I_S is the diode saturation current.

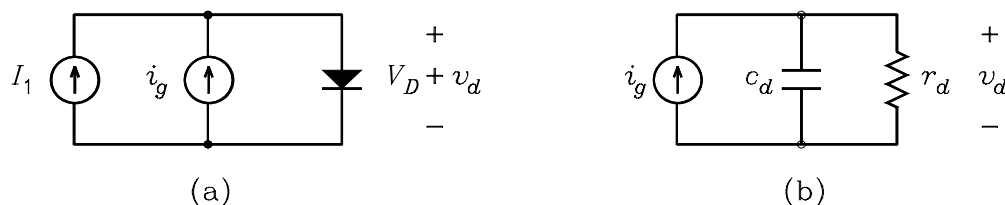

Figure 1.24: (a) Diode circuit for Example 5.8.2. (b) Small-signal equivalent circuit for derivation of the transfer function.

Solution. Denote the diode small-signal resistance by r_d and the small-signal diffusion capacitance by c_d . The small-signal circuit is shown in Fig. 1.24(b). From this figure, we can write

$$\frac{V_d}{I_g} = r_d \parallel \frac{1}{c_d s} = \frac{r_d}{1 + r_d c_d s}$$

For r_d and c_d , we have $r_d = \eta V_T / I_1$ and $c_d = \tau_F / r_d$, where Eqs. (1.24) and (1.49) have been used. It follows that the transfer function reduces to

$$\frac{V_d}{I_g} = \frac{\eta V_T}{I_1} \frac{1}{1 + \tau_F s}$$

This is of the form of a gain constant having the units of Ω multiplied by a low-pass filter transfer function. The gain constant is inversely proportional to I_1 . The time constant in the low-pass transfer function is independent of I_1 .

1.10 The Schottky Barrier Diode

Aluminum acts as a p-type impurity when in contact with silicon. Thus a p-n junction is formed when aluminum is deposited on an n-type silicon semiconductor. The diode is called a *Schottky barrier diode* or a *rectifying metal-semiconductor junction*. The major difference in the current versus voltage characteristics for a Schottky barrier diode and a junction diode is that the Schottky barrier diode has a lower cutin or threshold voltage. While the typical junction diode has a cutin voltage of approximately 0.5 V, the Schottky barrier diode has a cutin voltage of approximately 0.2 V. Thus

the Schottky barrier diode better approximates the current versus voltage characteristics of the ideal diode than does the junction diode.

Figure 1.25(a) shows the circuit symbol for the Schottky barrier diode. Its construction is illustrated in Fig. 1.25(b). The diode consists of two aluminum contacts deposited on an n-type silicon semiconductor. One contact forms the diode junction while the other is an ohmic contact. The surface area between the two contacts is covered with an insulating layer of silicon dioxide (SiO_2). The figure illustrates the basic difference between a rectifying and an ohmic contact. The ohmic contact has a layer of heavily doped n-type material beneath the contact that is called an n^+ region. In this region, the doping is so heavy that the metal-semiconductor junction is in Zener breakdown with no applied voltage. This causes the junction to exhibit a cutin voltage that is essentially zero. Because the junction exhibits a small residual resistance, it is called an ohmic contact.

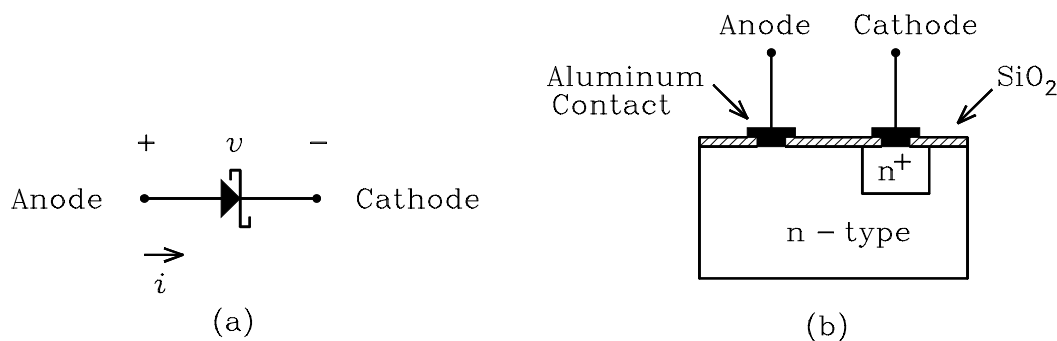

Figure 1.25: (a) Circuit symbol of the Schottky barrier diode. (b) Construction of the Schottky barrier diode.

The model equation for the current in the Schottky barrier diode is given by Eq. (1.1). The saturation current I_S in this equation is typically on the order of 10^4 times greater than that for the junction diode. It is the much larger saturation current of the Schottky barrier diode that causes the plot of its current versus voltage characteristic to exhibit a lower cutin voltage compared to the junction diode. The emission coefficient or ideality factor η is typically unity for the Schottky barrier diode.

Compared to the junction diode, the Schottky barrier diode has negligible diffusion charge when forward biased. Thus its switching speed is much faster than that of the junction diode. An important application of the Schottky barrier diode is in digital integrated logic circuits. The diodes are fabricated in parallel with the base-to-collector p-n junctions of bipolar junction transistors. The low cutin voltage of the Schottky barrier diode causes the diode to conduct before the transistor base-to-collector junction can conduct. This prevents the transistor from being driven into the saturation state. Because the switching speed of the Schottky barrier diode is so small, the addition of the diode to the transistor can considerably speed up the switching time of digital circuits.

1.11 The SPICE Diode Model

The basic model equations that are used in SPICE to simulate the diode have been covered in this chapter. Table 1.1 gives a listing of the diode model parameters, the default values used in SPICE, and example values that might be typical of a low-power integrated circuit switching diode.

Table 1.1: SPICE Diode Model Parameters

Symbol	Name	Parameter	Units	Default	Example
I_S	IS	Saturation Current	A	1.0E-14	1.0E-14
R_S	RS	Ohmic Resistance	Ω	0	10
η	N	Emission Coefficient		1	1
C_{j0}	CJO	Zero-Bias Depletion Capacitance	F	0	2.0E-12
V_B	VJ	Built-In Voltage	V	1	0.8
m	M	Grading Coefficient		0.5	0.5
τ_F	TF	Transit Time	s	0	1.0E-10

The resistor R_S models the series bulk ohmic resistance of the neutral regions on either side of the junction. The value may range from 10Ω to 100Ω , but a typical value is 10Ω .

1.12 Power Supply Rectifier Circuits

Practically all electronic circuits require a dc power source. With the exception of battery powered equipment, the dc power supply voltage is derived from an ac power line. A typical power supply consists of a transformer, a rectifier, and a filter circuit. The rectifier consists of one or more diodes. In this section, we cover some of the more common power supply rectifier circuits that are used in electronic circuits.

1.12.1 Half-Wave Rectifier

A *rectifier* is a two-terminal electronic device which passes a current in only one direction. The junction diode is an example of a rectifier. Fig. 1.26 shows the circuit diagram of a *half-wave rectifier* circuit consisting of a transformer, a diode rectifier, and a load resistor. The primary of the transformer is connected to an ac power line. We assume that the circuit seen looking into the transformer secondary can be modeled as an ac source having a zero output resistance. Thus the secondary voltage can be written

$$v_S(t) = V_1 \sin(\omega t) \quad (1.50)$$

where V_1 is the peak voltage and ω is the radian frequency. For $v_S(t)$ positive, the diode is forward biased and a current flows in the load resistor. For $v_S(t)$ negative, the diode is reverse biased and no current flows. The circuit is called a *half-wave rectifier* because the current flows only during alternate half cycles of the applied voltage.

To solve for the load current and voltage, we model the diode with the linear model given in Fig. 1.7. The circuit is shown in Fig. 1.27. The diode in this circuit is an ideal diode which has zero voltage across it when forward biased and zero current through it when reverse biased. The voltage V_{D0} models the threshold voltage of the diode and the resistance R_D models the change in

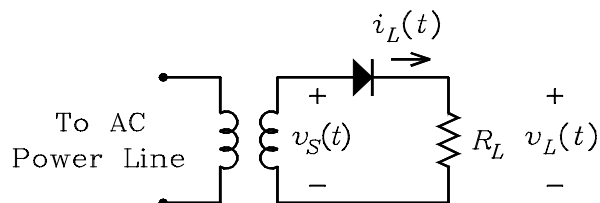

Figure 1.26: Half-wave rectifier circuit.

diode voltage with current. The load current and voltage in the circuit are given by

$$\begin{aligned} i_L(t) &= \frac{v_S(t) - V_{D0}}{R_D + R_L} \text{ for } v_S(t) \geq V_{D0} \\ &= 0 \text{ for } v_S(t) < V_{D0} \end{aligned} \quad (1.51)$$

$$v_L(t) = i_L(t) R_L \quad (1.52)$$

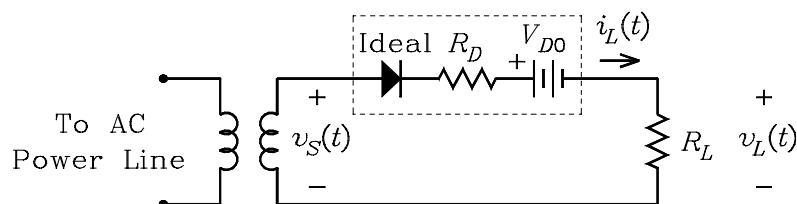

Figure 1.27: Model circuit for calculating the load current and voltage.

Fig. 1.28 shows plots of $v_S(t)$ and $v_L(t)$ as a function of time. Fig. 1.29 shows the same plots for the case where the direction of the diode in the circuit is reversed.

Half-Wave Rectifier with Capacitor Filter

Because the waveform for $v_L(t)$ in Fig. 1.28 is always positive, it contains a *dc component*. Because the voltage is not constant, it also contains an *ac ripple component*. To improve the operation of the circuit as a dc power supply, the ac ripple component must be reduced. This can be done by adding a *filter capacitor* in parallel with the load resistor. Such a circuit is shown in Fig. 1.30. When $v_S(t)$ increases to its peak value V_1 , the capacitor charges to a voltage that is approximately $V_1 - V_{D0}$. (This assumes that R_D is small.) When $v_S(t)$ decreases from its peak value, the diode becomes reverse biased. This forces the capacitor to discharge through the load resistor R_L . The discharge time constant of the circuit is $R_L C$. If this is large enough, the voltage on the capacitor decreases only a small amount during the time that the diode is reverse biased. During the next half cycle of the input voltage, the diode becomes forward biased again and the capacitor is recharges to the voltage $V_1 - V_{D0}$. Thus the load voltage can be made to remain approximately constant with the filter capacitor added to the circuit.

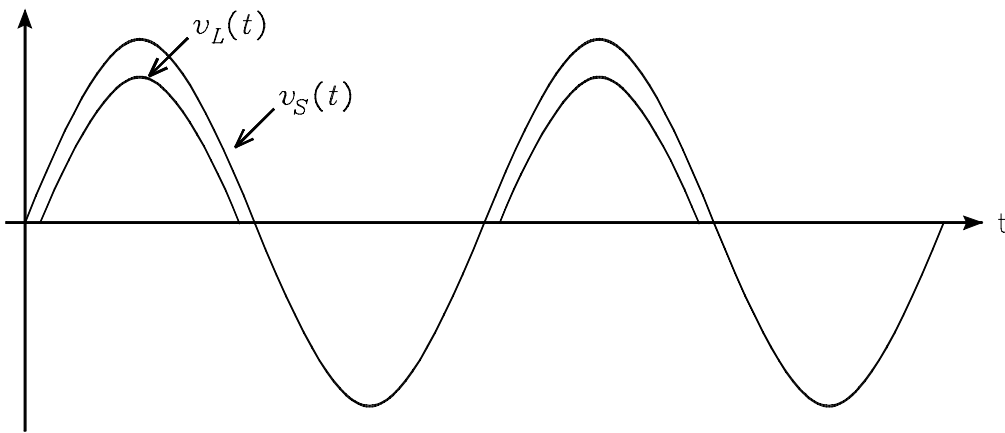

Figure 1.28: Waveforms for $v_S(t)$ and $v_L(t)$ for the half-wave rectifier circuit.

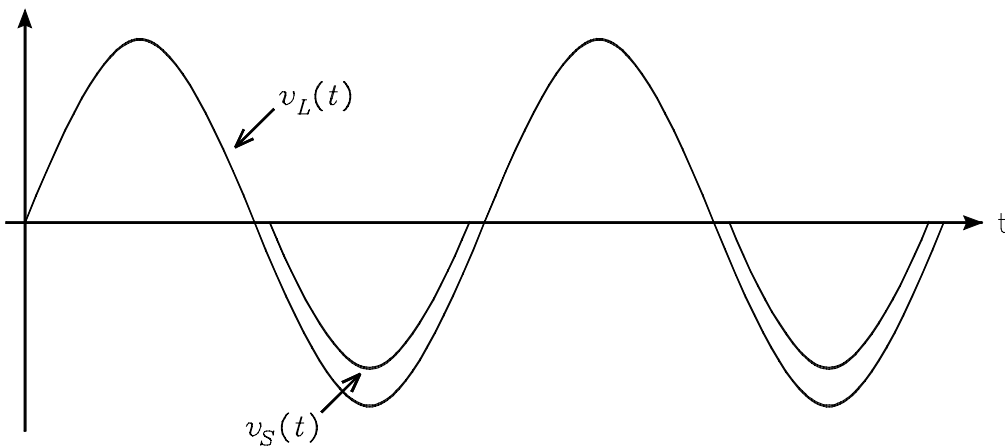

Figure 1.29: Waveforms for $v_S(t)$ and $v_L(t)$ if the direction of the diode is reversed.

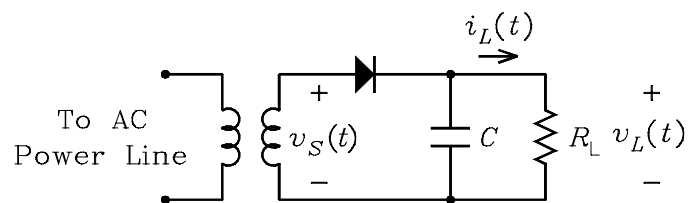

Figure 1.30: Half-wave rectifier circuit with capacitor filter.

Figure 1.31 shows the waveforms for the load voltage with the filter capacitor. During the interval $t_1 \leq t \leq t_2$, the diode is off and the voltage across the capacitor is given by

$$v_L(t) = (V_1 - V_{D0}) \exp\left(-\frac{t - t_1}{R_L C}\right) \quad (1.53)$$

The ac ripple voltage is defined as the difference between the maximum and minimum values of the load voltage and is given by

$$\begin{aligned} \text{AC Ripple Voltage} &= v_L(t_2) - v_L(t_1) \\ &= (V_1 - V_{D0}) \left[1 - \exp\left(\frac{-(t_2 - t_1)}{R_L C}\right) \right] \end{aligned} \quad (1.54)$$

Because $t_2 - t_1 \leq T = 1/f$, where T is the period of the ac input voltage and f is the frequency, it follows that

$$\text{AC Ripple Voltage} \leq \left[1 - \exp\left(\frac{-T}{R_L C}\right) \right] \quad (1.55)$$

It can be seen from this equation that the ac ripple voltage approaches zero as $C \rightarrow \infty$.

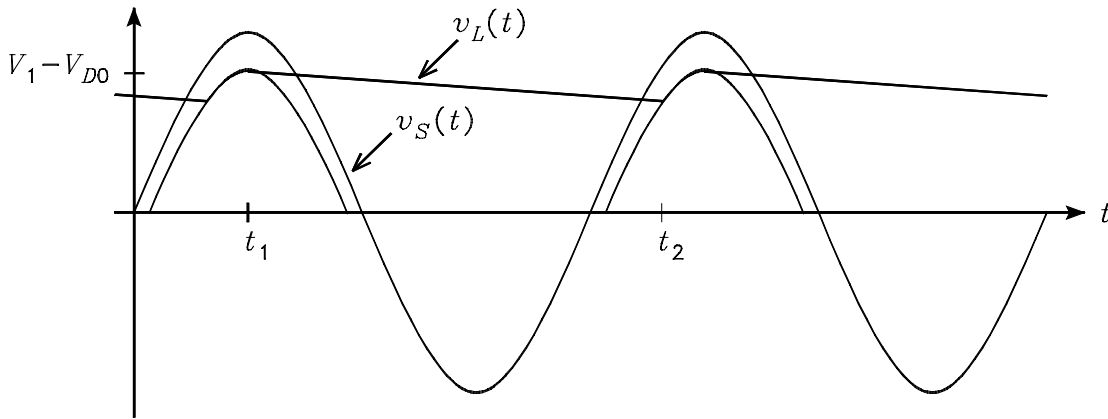

Figure 1.31: Waveforms for $v_S(t)$ and $v_L(t)$.

Percent Ripple

The *percent ripple* is defined as the ac ripple voltage expressed as a percent of the average or dc output voltage. The dc value is approximately equal to the peak value $V_1 - V_{D0}$. It follows from Eq. (1.55) that the percent ripple satisfies the inequality

$$\text{Percent Ripple} \leq \left[1 - \exp\left(\frac{-T}{R_L C}\right) \right] \times 100\% \quad (1.56)$$

This equation is useful for design purposes because the actual percent ripple is always less than the value predicted by the equation.

Example 11 The dc power supply circuit of Fig. 1.30 is to be designed for the following specifications: dc output voltage = +15 V, dc load current = 100 mA, and percent ripple = 5%. The rectifier diode can be modeled with the parameters $V_{D0} = 0.7$ V and $R_D = 0$. Calculate the required transformer secondary ac rms voltage and the value of the filter capacitor. Assume a frequency $f = 60$ Hz.

Solution. The peak secondary transformer voltage is given by $V_1 = 15 + 0.7 = 15.7$ V. The ac rms voltage is $15.7/\sqrt{2} = 11.1$ V rms. The effective value of the load resistor is $R_L = 15/0.1 = 150$ Ω . The value of C can be calculated from Eq. (1.56), where equality is used in the equation. We obtain

$$C = \frac{T}{R_L} \frac{-1}{\ln(1 - \% \text{ ripple}/100)} = \frac{1/60}{150} \frac{-1}{\ln(1 - 5/100)} = 2170 \mu\text{F}$$

It follows from the inequality in Eq. (1.56) that this value for C gives a percent ripple that is less than 5%.

1.12.2 Full-Wave Rectifier

In a half wave rectifier circuit, current flows only during alternate half cycles of the ac input voltage. In a full-wave rectifier circuit, current flows every half cycle of the ac input voltage. Fig. 1.32 shows the circuit diagram of a full-wave rectifier circuit. It consists of a transformer having a center-tapped secondary and two rectifier diodes. The upper half of the transformer secondary drives diode D_1 and the lower half of the secondary drives D_2 . The voltage applied to D_2 is the negative of the voltage applied to D_1 . It follows that D_1 is conducting when D_2 is not conducting and vice versa. Fig. 1.33 shows the waveform of the load voltage. Compared to the half-wave rectifier, the dc or average value of the load current doubled. The polarity of the output voltage is reversed if the directions of the two diodes in the circuit are reversed.

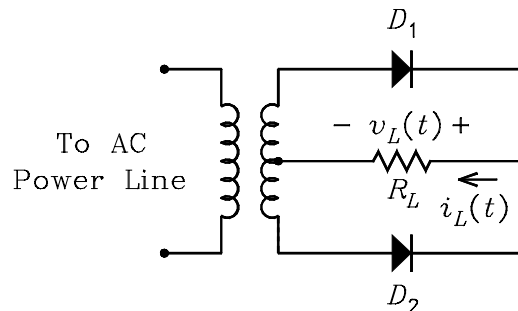

Figure 1.32: Full wave rectifier circuit.

Full-Wave Rectifier with Capacitor Filter

The ac ripple voltage on the load can be decreased by adding a filter capacitor to the full-wave rectifier circuit. The circuit is shown in Fig. 1.34. The waveform for the load voltage is shown in

Figure 1.33: Waveform for $v_L(t)$.

Fig. 1.35. Compared to the half-wave rectifier with filter capacitor, the time interval during which the capacitor discharges is halved. Thus the percent ripple satisfies the inequality

$$\text{Percent Ripple} \leq \left[1 - \exp\left(\frac{-T}{2R_L C}\right) \right] \times 100\% \quad (1.57)$$

For a given percent ripple, it follows that the required value of the filter capacitor in the full-wave rectifier is one-half the value of the filter capacitor in the half-wave rectifier.

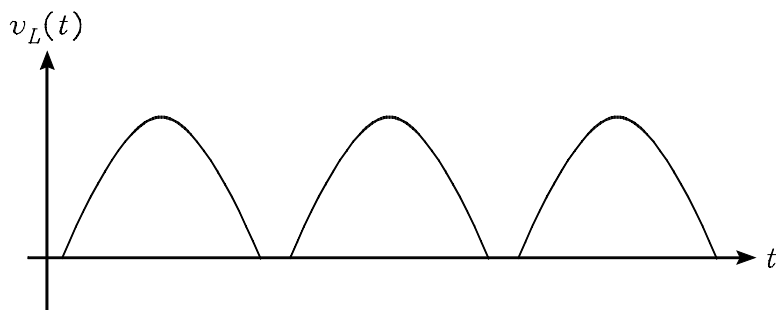
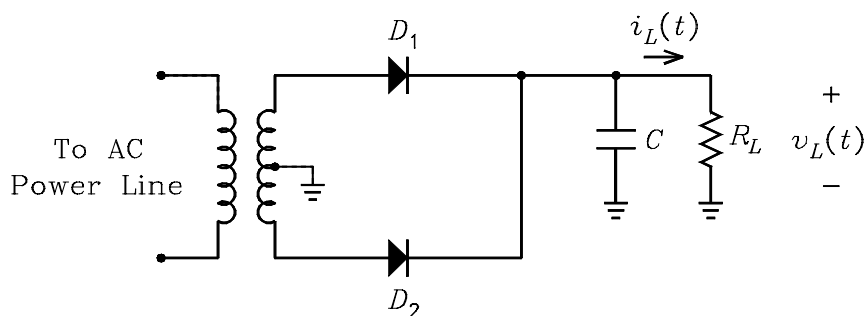

Figure 1.34: Full-wave rectifier circuit with capacitor filter.

Bridge Rectifier Circuit

Many analog circuits require bipolar power supply voltages. Fig. 1.36 shows the circuit diagram of a bipolar power supply consisting of a center-tapped transformer, four diodes, and two filter capacitors. Diodes D_1 and D_2 operate as a full-wave rectifier with a positive output voltage. Diodes D_3 and D_4 operate as a full-wave rectifier with a negative output voltage. The four diodes in combination are called a bridge rectifier. The circuit diagram shows a capacitor C_3 connected across the ac input of the bridge rectifier. This capacitor is often included in such circuits to suppress undesirable radio frequency radiation generated by the switching of the diodes. This radiation can cause interference with radio receiver sets in the vicinity of the power supply. A typical value of this capacitor is in the range from $0.01 \mu\text{F}$ to $0.1 \mu\text{F}$.

Figure 1.35: Waveform for $v_L(t)$.

Figure 1.36: Bridge rectifier circuit with filter capacitors.

Example 12 An audio amplifier requires a bipolar power supply that puts out $+45\text{ V}$ and -45 V with a maximum average full load current of 1.6 A from each side of the supply. It is estimated that the power supply voltages drop by 15% for full load current compared to no load current. The rectifier diodes can be modeled with the parameters $V_{D0} = 0.7\text{ V}$ and $R_D = 0$. If the average full load current from each side of the supply can be considered to be a dc current, calculate the no load ac rms secondary voltage rating of the transformer and the value of the filter capacitors which give less than 10% ripple voltage.

Solution. The no-load peak input voltage to each full-wave rectifier is $V_1 = 45/(1 - 0.15) + 0.7 = 53.6\text{ V}$. The no-load rms voltage rating of each side of the transformer secondary is $53.6/\sqrt{2} = 37.9\text{ V}$. The no-load rms secondary voltage rating of the transformer is obtained by doubling this to obtain $2 \times 37.9 = 75.8\text{ V}$. The effective value of the load resistance on each side of the power supply is $R_{L1} = R_{L2} = 45/1.6 = 28.1\ \Omega$. The value of each filter capacitor can be calculated from Eq. (1.57), where equality is used in the equation. We obtain

$$C_1 = C_2 = \frac{T}{2R_L} \times \frac{-1}{\ln(1 - \% \text{ ripple}/100\%)} = \frac{1/60}{2 \times 28.1} \times \frac{-1}{\ln(1 - 10/100)} = 2815\ \mu\text{F}$$

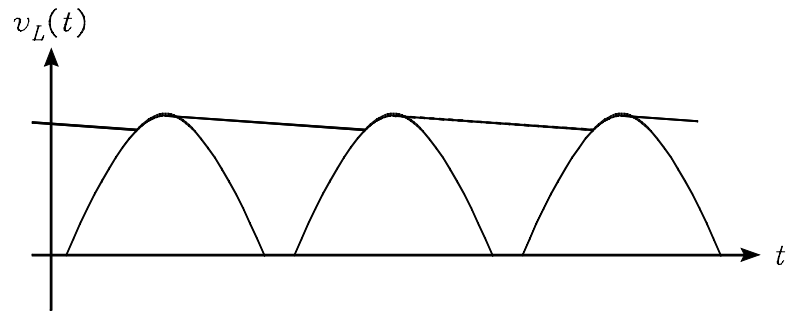
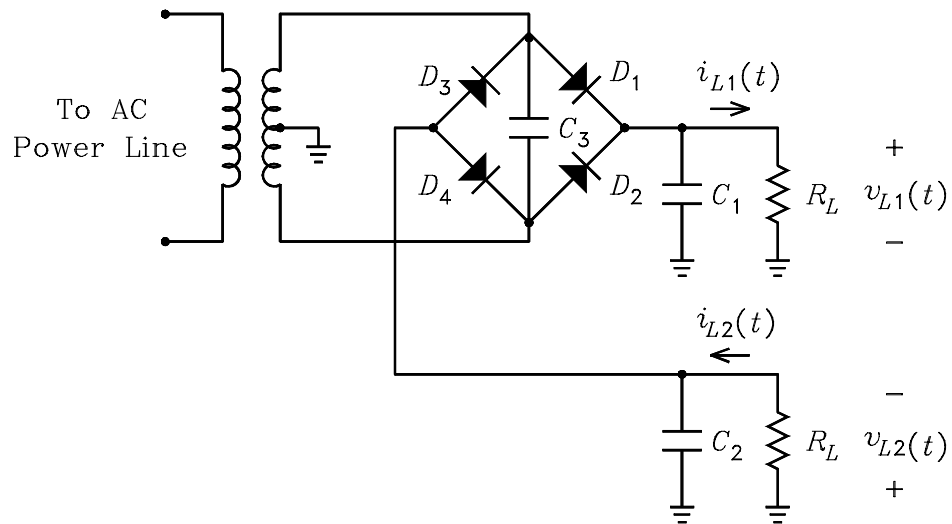
It follows from the inequality in Eq. (1.57) that this value for the capacitors gives a percent ripple that is less than 10%.

1.12.3 Full-Wave Rectifier without a Center-Tapped Transformer

Figure 1.37 shows the circuit diagram of a diode bridge rectifier that does not require a transformer with a center-tapped secondary. When $v_S(t)$ is positive, diodes D_1 and D_4 conduct to supply positive load current. When $v_S(t)$ is negative, diodes D_2 and D_3 conduct to supply positive load current. Because there are two series diodes in each path, the capacitor charges to the peak voltage of $v_S(t)$ minus the drops across two forward biased diodes.

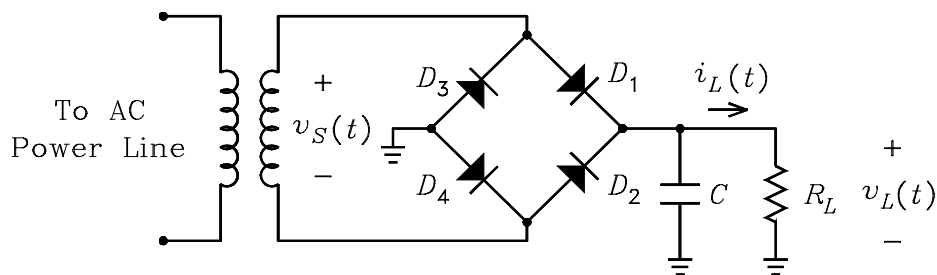

Figure 1.37: Full-wave bridge rectifier that requires no transformer center tap.

1.13 Diode Clipper Circuits

1.13.1 Peak Clipper

A *peak clipper* is a circuit that clips off or removes the peaks from a signal waveform. Such circuits are often used at the input to an amplifier to prevent the application of a large amplitude

signal which could damage the amplifier input stage. Fig. 1.38(a) shows the circuit diagram of a diode clipper. To explain the operation of the circuit, we first consider the two diodes to have the characteristics of an ideal diode. For $v_I = 0$, diode D_1 is reverse biased by the positive bias voltage applied to its cathode and D_2 is reverse biased by the negative bias voltage applied to its anode. Because no current flows in the circuit, the output voltage is zero. If v_I is made positive, v_0 increases. This causes the reverse bias voltage across D_1 to decrease and the reverse bias voltage across D_2 to increase. If v_I is not large enough to forward bias D_1 , no current flows in the circuit so that $v_0 = v_I$. If $v_I > V_B$, D_1 becomes forward biased. Because the voltage across a forward biased ideal diode is zero, it follows that $v_0 = +V_B$. Similarly, if v_I is negative, $v_0 = v_I$ for $v_I \geq -V_B$. If $v_I < -V_B$, D_2 is forward biased and $v_0 = -V_B$. Thus the output voltage is limited to the range $-V_B \leq v_0 \leq +V_B$. Because of the limited output voltage range, the circuit is also called a *limiter* circuit.

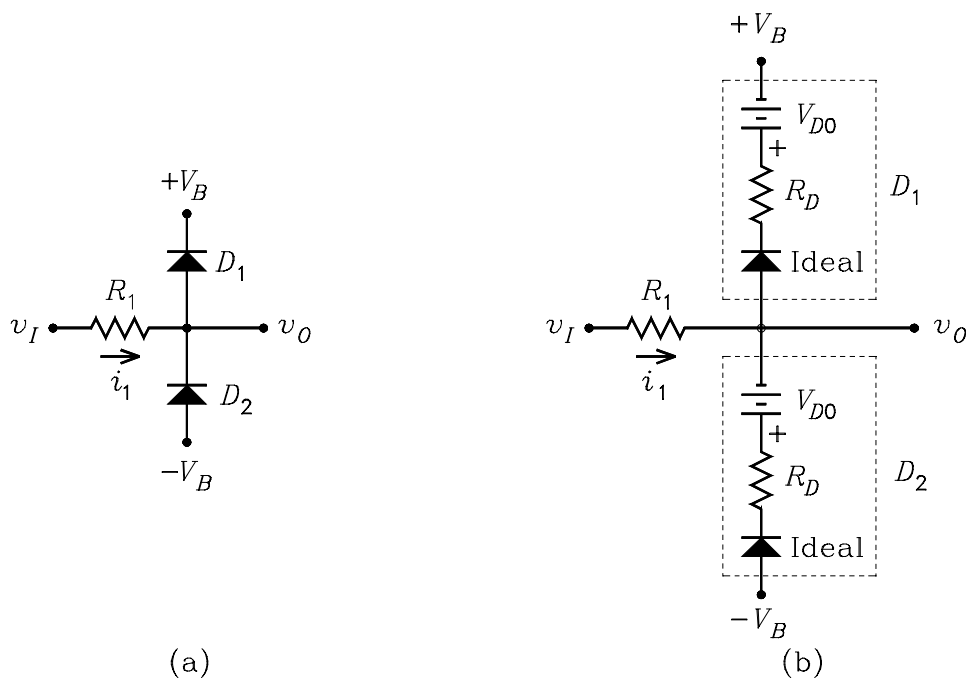

Figure 1.38: (a) Circuit diagram of a diode clipper. (b) Circuit with the diodes replaced by piecewise linear models.

For a more accurate analysis of the circuit, we model the diodes with its large-signal piecewise linear model in Fig. 1.7. The circuit is shown in Fig. 1.38(b). For $-(V_B + V_{D0}) < v_I < +(V_B + V_{D0})$, both diodes are reverse biased and $v_0 = v_I$. For $v_I \geq V_B + V_{D0}$, D_1 is forward biased. In this case, the input current i_1 and the output voltage v_0 are given by

$$i_1 = \frac{v_I - (V_B + V_{D0})}{R_1 + R_D} \quad (1.58)$$

$$v_0 = v_I - i_1 R_1 = (V_B + V_{D0}) \frac{R_1}{R_1 + R_D} + v_I \frac{R_D}{R_1 + R_D} \quad (1.59)$$

Similarly for $v_I \leq -(V_B + V_{D0})$, D_2 is forward biased and v_0 is given by

$$v_0 = -(V_B + V_{D0}) \frac{R_1}{R_1 + R_D} + v_I \frac{R_D}{R_1 + R_D} \quad (1.60)$$

Figure 1.39(a) shows the plot of v_0 versus v_I for the clipper. Because the slope of the curve is unity when both diodes are off, it follows that $v_0 = v_I$ at the point where either diode just becomes forward biased. When either diode is conducting, the slope of the curve is $R_D/(R_1 + R_D)$. For $R_1 \gg R_D$, the slope is very small so that the curve is almost horizontal. Fig. 1.39(b) shows output voltage waveforms from the clipper for two sine-wave input signals. The lower amplitude signal has a peak value less than the clipper threshold so that it is unclipped. The larger amplitude signal is clipped. It can be seen that the clipping is symmetrical. If unsymmetrical clipping is desired, unequal bias voltages can be used on the two diodes.

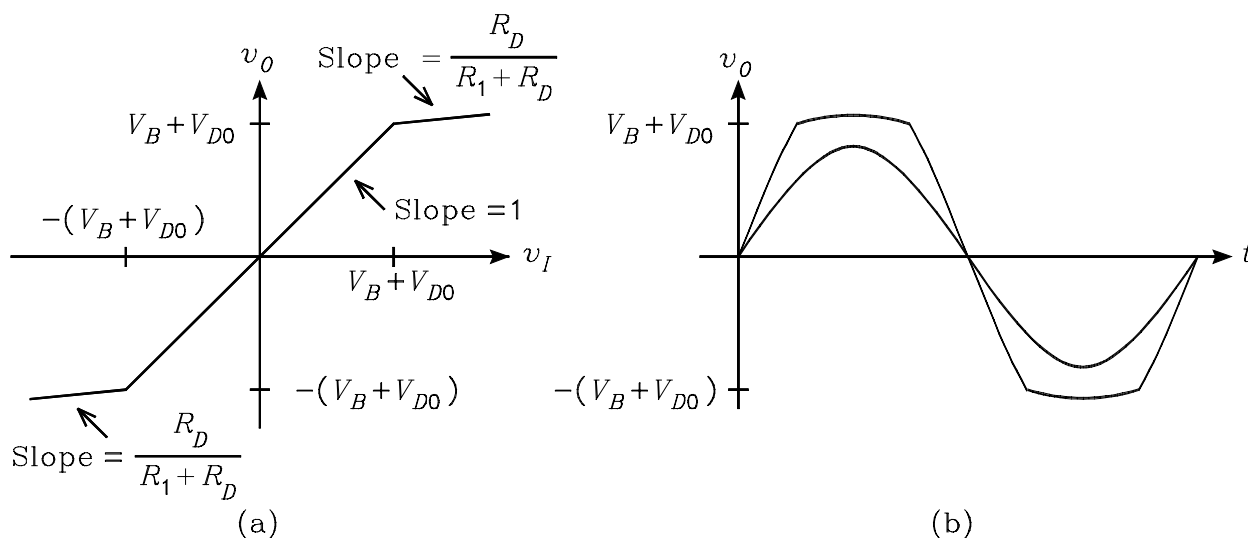

Figure 1.39: (a) Output voltage versus input voltage for the peak clipper. (b) Output voltage waveforms for a sine wave input signal.

Because the piecewise linear model of the diode is an approximation, the curve in Fig. 1.39(a) is only approximate. With physical diodes, the curve would exhibit a gradual change in slope at the points where the diodes become forward biased. Because the slope of the curve is never zero in the regions where either diode is forward biased, the clipper circuit is said to be a *soft clipper*. The slope in these regions can be increased by adding resistors in series with the diodes.

A consideration in the design of clipper circuits is the switching speed of the diodes. Rectifier diodes fabricated for use in power supply circuits that are powered from a 60 Hz ac line do not have a fast enough switching speed to be used at frequencies in the upper audio frequency band. When the switching speed is a consideration, either fast recovery rectifier diodes, fast switching diodes, or shottky barrier diodes should be used in the circuits.

1.13.2 Center Clipper

A *center clipper* is a circuit that clips out or removes the center portion from a signal waveform. Fig. 1.40(a) shows the circuit diagram of a center clipper. To explain the operation of the circuit, we first consider the four diodes to be ideal. If v_I is positive and greater than V_B , diodes D_1 and D_2 are forward biased and D_3 and D_4 are reverse biased. Current flows from the source, up through D_1 , down through V_B , up through D_2 , and down through R_L . Because an ideal diode has no voltage across it when it is forward biased, it follows that $v_0 = v_I - V_B$. If the input voltage is decreased to the value $v_I = V_B$, v_0 decreases to zero. At this point, the voltage across and the current through D_1 and D_2 are zero. If v_I is decreased further, D_1 and D_2 cut off. No current flows in the circuit and the output voltage is zero.

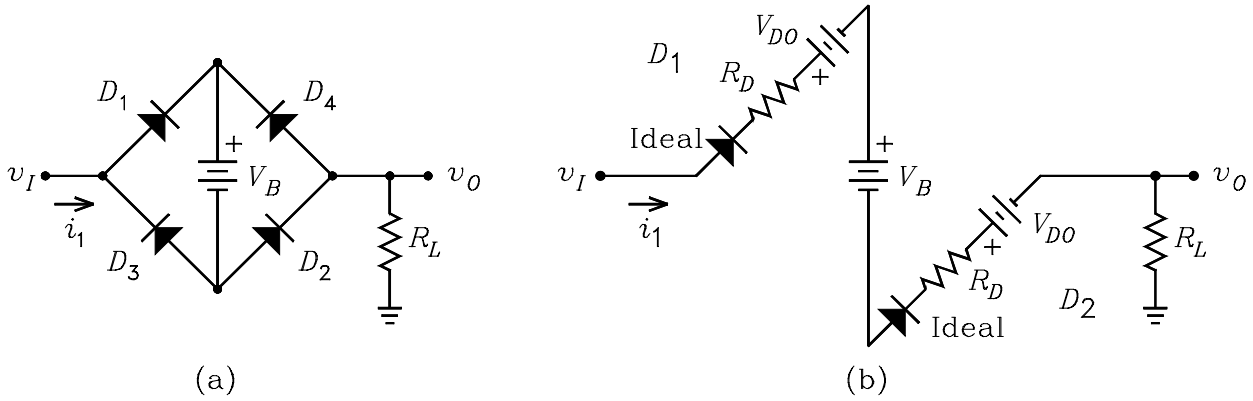

Figure 1.40: (a) Circuit diagram of the center clipper. (b) Circuit for $v_I > V_B + 2V_{D0}$ and the diodes replaced with piecewise linear models.

Similarly, for v_I negative and less than $-V_B$, D_1 and D_2 are reverse biased and D_3 and D_4 are forward biased. Current flows up through R_L , up through D_4 , down through V_B , up through D_3 , and into the source. The output voltage is given by $v_0 = v_I + V_B$. If the input voltage is increased to the value $v_I = -V_B$, v_0 increases to zero. At this point, the voltage across and the current through D_3 and D_4 are zero. If v_I is increased further, D_3 and D_4 cut off. No current flows in the circuit and the output voltage is zero. It follows that $v_0 = 0$ for $|v_I| \leq 0$.

For a more accurate analysis of the circuit, we model the diodes with the piecewise linear model of Fig. 1.7. Let us assume that v_I is positive and large enough to produce an output. In this case, diodes D_1 and D_2 are forward biased and D_3 and D_4 are reverse biased. The equivalent circuit is shown in Fig. 1.40(b). For $v_I \geq V_B + 2V_{D0}$, the input current i_1 and the output voltage v_0 are given by

$$i_1 = \frac{v_I - V_{D0} - V_B - V_{D0}}{R_D + R_L + R_D} \quad (1.61)$$

$$v_0 = i_1 R_L = [v_I - (V_B + 2V_{D0})] \frac{R_L}{2R_D + R_L} \quad (1.62)$$

Similarly for $v_I \leq -(V_B + 2V_{D0})$, D_1 and D_2 are reverse biased and D_3 and D_4 are forward biased.

It follows by symmetry that the output voltage is given by

$$v_0 = [v_I + (V_B + 2V_{D0})] \frac{R_L}{2R_D + R_L} \quad (1.63)$$

For $|v_I| < V_B + 2V_{D0}$, it follows that $v_0 = 0$.

Fig. 1.41(a) shows the plot of the output voltage versus input voltage for the center clipper. The region defined by $|v_I| < V_B + 2V_{D0}$ is called a *deadband region*. It is called this because $v_0 = 0$ in this region. For $|v_I| \geq V_B + 2V_{D0}$, the slope of the curve is $R_L / (2R_D + R_L)$. For $R_L \gg 2R_D$, the slope is approximately unity. Fig. 1.41(b) shows the output voltage waveform for a sine-wave input signal. The waveform illustrates why the circuit is called a center clipper. The center portion of the sine wave is clipped out. The waveform distortion that is introduced by the center clipper is sometimes called *crossover distortion*. It is called this because the distortion occurs when the waveform crosses the horizontal axis.

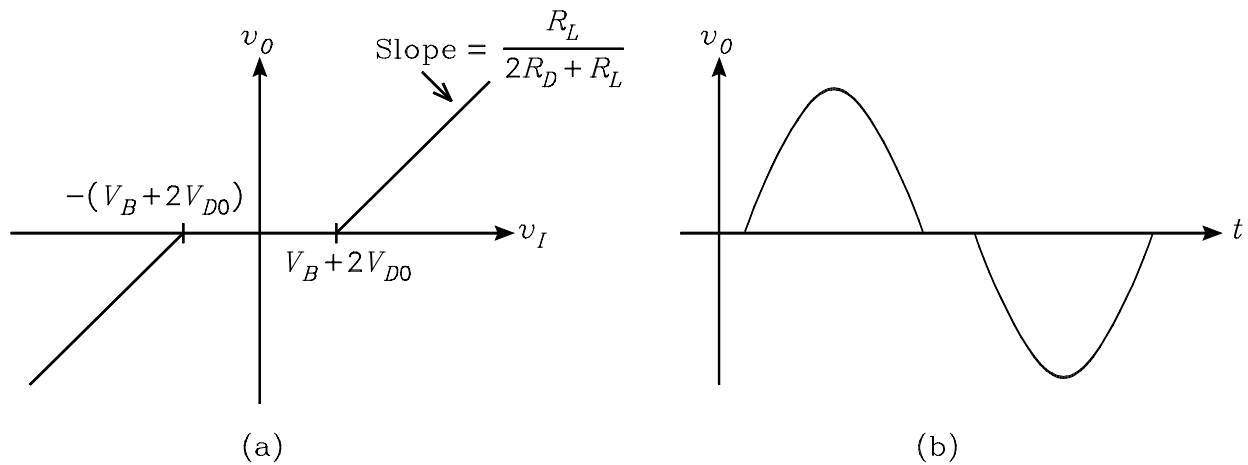

Figure 1.41: (a) Output voltage versus input voltage for the center clipper. (b) Output voltage waveform for a sine wave input signal.