

Six Time- and Frequency-Selective Empirical Channel Models for Vehicular Wireless LANs

Guillermo Acosta-Marum, *Member, IEEE*, and Mary Ann Ingram, *Member, IEEE*

Abstract— Three vehicle-to-vehicle (VTV) models and three roadside-to-vehicle (RTV) models, each suitable for RF channel emulation and based on measurements at 5.9GHz, are presented. Each model captures the joint Doppler-delay characteristics of a different environment. The packet error rate (PER) for each model, measured with an emulator and a 802.11p Wireless Access in Vehicular Environments (WAVE) prototype, is presented.

Index Terms—doubly selective wireless propagation models, intelligent transportation, mobile-to-mobile WLANs.

I. INTRODUCTION

We present six small-scale fading models created in support of the IEEE 802.11p Wireless Access in Vehicular Environments (WAVE) / Dedicated Short Range Communications (DSRC) Standard [1]. The models are to be used as the basis for the motion-related equipment certification test for the standard. These models are suitable for certain commercial RF channel emulators and computer simulators. The modulation for 802.11p is orthogonal frequency division multiplexing (OFDM) at 5.9 GHz, with a bandwidth of 10 MHz. Therefore, the channels for 802.11p are doubly selective, which means they are both time- and frequency-selective. Applications for 802.11p include transportation safety (e.g. alerts for approaching emergency vehicles), toll collection, and commercial services.

Previous work related to VTV measurement and modelling include theoretical 2-D [2] and 3-D [3] VTV models, flat-fading VTV measurements for the highway [4], and doubly selective models for the roadside-to-vehicle channel [5]. In [5], the authors report Doppler spectrum shapes, but they do not describe how those shapes were determined. Power delay profiles (PDPs) and tap fading statistics were reported in [6]. Preliminary models based on measurements taken in 2003 at 2.4 GHz of the expressway with same-direction travel and a high middle wall were reported in [7], [8] and [9]. [8] and [9] report attempts to capture the wide range of link BER variation with a collection of tapped delay lines.

II. MODEL DEVELOPMENT

The type of model we consider is the tapped delay line, where each tap process is described as having Rician or

TABLE I

DEVELOPED MODELS			
SCENARIO	DISTANCE BETWEEN TX AND RX (m)	NO. OF TAKES USED IN MODEL	AVERAGE PER RESULT (%)
VTV - Expressway Oncoming	300-400	4	5.6
VTV - Urban Canyon Oncoming	100	2	4.4
RTV - Suburban Street	100	10	3.0
RTV - Expressway	300-400	8	2.7
VTV - Expressway Same Direction With Wall	300-400	21	1.9
RTV - Urban Canyon	100	4	0.8

Rayleigh fading, and by a Doppler power spectral density (PSD). Certain RF channel emulators, such as the SPIRENT 5500 [10], and certain communication system simulators, such as MATLAB Simulink, describe doubly selective channels in terms of “paths,” where the Doppler PSD of each path is described as having one of a small collection of shapes, such as “Classic 6 dB,” “Rounded,” or “Flat” [10]. Other path parameters include the shape’s width, center frequency, excess delay, and area (*i.e.* path power). One can craft a “composite” tap PSD by assigning several paths with different shapes to have the same excess delay. However, an RF channel emulator has only a finite number of paths; older models have only 12 paths and newer models, such as the 5500, have 24 paths. Therefore, in defining channel models for this type of channel emulator, only one to three paths per tap should be used.

The models enlisted in

Table I represent six of the environments or scenarios in which the WAVE/DSRC system is expected to operate; three of them are for the VTV link, and the other three are for the roadside-to-vehicle (RTV) link. For each model, we indicate the distance between the transmitter (TX) and the receiver (RX), the number of takes we used to develop the model, and the average PER obtained when we emulated the model with transmitted 1,000 Byte physical layer service data units (PSDUs) at 6 Mbps. A “take” is one event of driving by the location, and it consists of 9.6 seconds of recorded data, which corresponds to approximately 83,500 measured channel impulse responses.

For the certification test, the WAVE/DSRC equipment is to be operated using an RF channel emulator over the specified channel for at least 5 seconds, for packets with a given PSDU size, and the PER is to be recorded. The equipment passes if the PER under the specified conditions is less than 10%.

Guillermo Acosta-Marum and Mary Ann Ingram are with School of Electrical and Computer Engineering at Georgia Institute of Technology, Atlanta, GA 30332-0250 USA (e-mail: gacosta@gatech.edu, and mai@ece.gatech.edu).



Fig. 1: Scenarios examples

These small-scale fading models represent multipath fading effects only and do not include path loss or lognormal shadowing. The models are based on data which was measured in Spring 2006 at a frequency of 5.9 GHz in the metropolitan Atlanta, Georgia area. Details on the measurement and signal processing techniques can be found in [11]. The vehicle speeds during measurement were approximately 105 km/h (65 mph) for the expressway and 32 km/h to 48 km/h (20 mph to 30 mph) for the surface streets. For the models in this report, the Doppler frequencies were scaled to be consistent with vehicle speeds of 140 km/h for the expressway and 120 km/h (72 mph) for the surface streets.

The biggest challenge in selecting locations for the measurements was finding straight roads to enable line-of-sight (LOS) conditions. Unless otherwise noted, magnetically mounted monopole antennas were used for the measurements.

A. Scenario Descriptions

1) VTV Expressway Oncoming

For this scenario, we found a stretch of highway without a middle wall on GA 675 between Exits 5 and 7. For the measurement, we synchronized each of the vehicles so that they entered the highway at the same time. We then accelerated each one to 65 mph, and at the appropriate distance, we began recording. In Fig. 1a, we show an instance when we had the required separation between the vehicles. The traffic conditions shown in the picture were typical for all the “takes.”

2) VTV Urban Canyon Oncoming

For this scenario, it was very difficult to find a location with the urban canyon characteristics that allowed the required 20-30 mph speed. The best location we could find was Edgewood Avenue in Downtown Atlanta. In Fig. 1b, we show the starting point of the receiver vehicle. From the figure, we can notice that to reach the required speed, we had to synchronize the vehicles’ movement to the traffic lights. Because of the dense traffic, we required a considerable time to set up the vehicles

for a “take.”

3) RTV Suburban Street

For these measurements, the transmitting antenna was mounted on a pole near the intersection of Memorial Drive and Columbia Drive, as shown in Fig. 1c. The antenna was at 6.1 m (20 feet) high. The target range was 100m. The receiver vehicle approached the intersection from the four possible directions. We started each “take” when the receiver vehicle reached the required 20-30 mph speed and desired the range.

4) RTV Expressway

For this scenario, the transmitting antenna was mounted on a pole off the side of the GA 78 expressway, as shown in Fig. 1d. The antenna was 6.1 m (20 feet) high. A half-dome antenna was used for these measurements. Measurements were taken as the vehicle approached from both directions on the expressway. We coordinated the start of the recordings to initiate when the receiver vehicle reached 65 mph and desired range.

5) VTV Expressway Same Direction with Wall

This scenario contains data measured at many different locations along various expressways in Atlanta, Georgia. However, all locations had a center wall between oncoming lanes as shown in Fig. 1e. Of all the scenarios, this was the easiest to record. For each “take,” we only had to verify the 300-400 m separation since most of the time we were able to maintain the required 65 mph speed and desired range.

6) RTV Urban Canyon

For this scenario, the transmitting antenna was mounted on a pole near the urban intersection of Peachtree Street with Peachtree Circle, as shown in Fig. 1f. The antenna was 6.1 m (20 feet) high. The target range was 100 m. For the measurement, we had to wait for the traffic lights and traffic conditions to allow us to initiate a “take” when the receiver vehicle attained the required 20-30 mph speed with the desired range.

B. PER Test Procedure

This section gives a high-level description of the test setup that was used to measure the PER for each model in this report. The testing approach was based on the “ping” application of the IPv6 protocol. The test was demonstrated using two prototypes of WAVE/DSRC units defined as on-board unit (OBU) and road-side unit (RSU) supplied by Mark IV and Transcore. Network interface programs were provided by Transcore and C++ TX and RX PER measurement programs were written at Georgia Tech. The channel models were implemented using a SPIRENT SR5500 RF Channel emulator. The main PER measurement parameter provided by the developed software was the cumulative PER (CPER) defined as the percentage of missing packets with respect to the total number of sent packets.

A block diagram of the setup is shown in Fig. 2. The RSU was configured as the TX and the OBU was configured as the RX. The ping application required a bidirectional connection. Because the channel emulator is unidirectional, a feedback path was created using isolators and circulators.

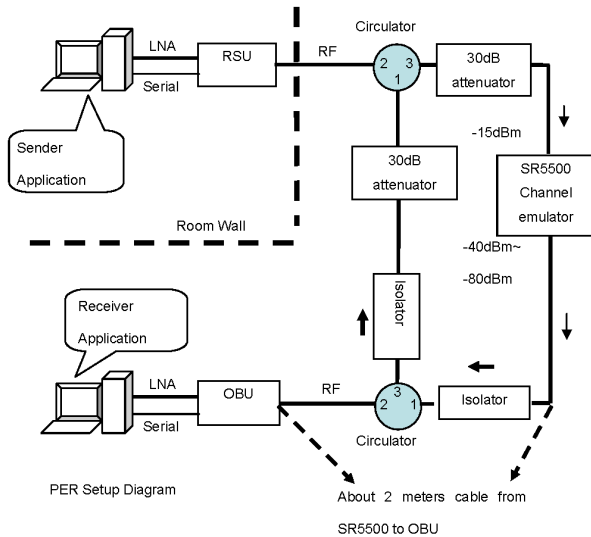

Fig. 2. PER system setup

1) Initial Setup

After making sure that the prototype units with cables connected instead of antennas did not have any RF leakage, we started our testing by identifying the sensitivity threshold (ST) of the receiver, i.e., the input level when noise will produce a non-zero PER. To obtain this parameter, we used a minimal configuration, i.e., we just connected both units with a single coaxial cable where we had a 60 dB variable attenuator. We then attached fixed attenuators until we could find the ST within the range of the variable attenuator. The result for this initial setup was 107 dB of attenuation required to obtain the ST, which if we consider the +20 dBm specified power output of the unit, gives us a -87 dBm ST. For the next setup, we introduced all the circulators and isolators that we use for the emulator configuration. We put the variable attenuation in the RSU-OBU path, which is the channel emulator path. For this

case, the attenuation obtained at the ST was 103 dB. This means that there is a loss of 5 dB in the extra cables and RF devices.

Finally, we introduced the Spirent SR5500 channel emulator in the RSU-OBU path. According to the Spirent specifications, the best input level for optimal performance is a nominal -10 dBm; therefore, if we assume that the indicated output power of the units to be correct at +20 dBm, we have to lower the input to the channel emulator with a fixed 30 dB attenuator. With this nominal input level, we proceed to investigate if the maximum attenuation produced by the channel emulator will be lower than the ST. We set the channel emulator to produce a static path without any relative loss or modulation. We then setup the output power to its minimum, which indicated an output of -79.5 dB. We did not achieve the ST at this maximum attenuation. Not only that, we obtained 0 % PER; therefore, we can be confident that any PER produced will be produced by the dispersions of the emulated channel.

In Fig. 3, we show representative results of three PER tests with a 1,000 Byte PSDU at 6 Mbps. For each test, we recorded the PER of ten sets of 20,000 transmitted packets. As we can see in Fig. 3, each test produces a tight fit to the set mean after the first 10,000 packets.

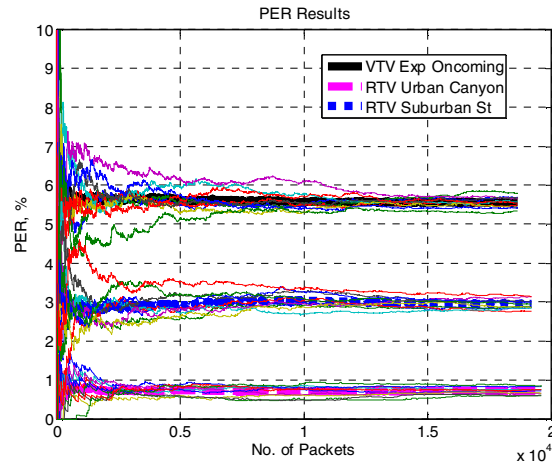

Fig. 3. PER results for three models

III. MODEL DESCRIPTIONS

In Table II, we show the RF channel emulator parameters for the six models. Each set of the parameters “Frequency Shift,” “Fading Doppler,” and “Fading Spectral Shape” describe a single simple Doppler spectrum. Respectively, these parameters mean center (baseband) frequency, frequency half-width of the spectrum, and the basic shape of the spectrum. The fact that the first two cells in the “Tap No.” column are “1” and “1,” while the first two cells in the path column are “1” and “2,” imply that all six models have a composite spectrum on the first tap, comprising at least two simple spectrum shapes. Whenever a six-element vector is given in one of the cells, the i^{th} element corresponds to the i^{th} model, as indicated in Note 1 below the table.

Each model is normalized so that the first tap power is 0 dB.

As mentioned before, a tap is constructed from several paths of the channel emulator because of the limited choices for the spectral shapes of paths that are quite insufficient to describe many of the measured tap Doppler spectra. By superimposing several paths with nearly the same delay, it is possible to create a customized Doppler spectrum that fits better. To avoid problems with the channel emulator, paths comprising a single tap were separated in delay by one nanosecond. The customized Doppler spectrum is constrained to have the same total power (i.e. same area in a non-dB plot) as the measured Doppler spectrum, so that the power delay profile is preserved.

Before fitting spectral shapes to the measured spectra, the deterministic part of the Doppler spectrum, usually the LOS component, is removed [11], leaving what we term the “random spectrum.” Examples of random (blue) and fitted (red) spectra are presented in Fig. 4. After fitting, the frequency values are scaled up to the values shown in the table, to be consistent with the vehicle speeds specified in the standard.

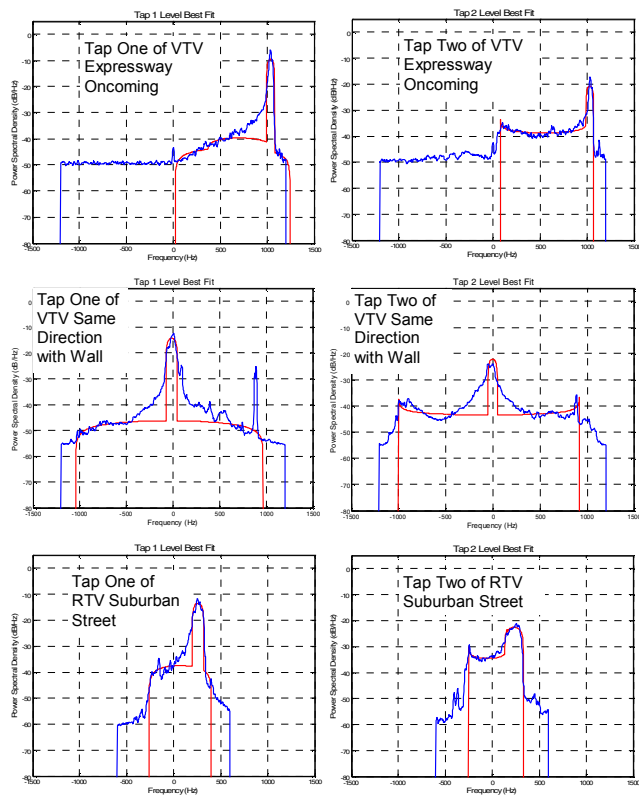

Fig. 4. Examples of fitting to the random part of the measured spectra.

Each tap spectrum fit was optimized by taking the best of five runs of the genetic algorithm. The cost function used in the genetic algorithm and for selecting the best of the five was the integrated weighted difference between the measured spectrum and the customized spectrum. The weighting function was $(f - f_{peak})^2$, where f_{peak} is the frequency of the peak (usually very well defined) of the spectrum of the first (and strongest) tap. It is assumed that f_{peak} is the recovered carrier frequency in the receiver. The cost function ensures that the inter-carrier interference (ICI) that would be produced by the customized

spectrum in an OFDM receiver is as close as possible to the ICI produced by the measured spectrum [11], [12]. For a Rician tap, one of the paths in the customized spectrum is somewhat arbitrarily selected to be Rician and the others are set to be Rayleigh faded. The deterministic power (i.e. the numerator of the K factor) of the tap becomes the deterministic power of the Rician path.

IV. DISCUSSION

PER generally decreases with decreasing Doppler offsets and widths, and increasing K factors. Next we discuss each of the models in order of decreasing PER. We will give the K factors of each overall model (i.e. the ratio of the deterministic power over the total random power of all taps). We will also note the values of maximum delay, although this parameter does not have a strong impact on PER.

VTV-Expressway Oncoming has the biggest offset, coupled with wide tap spectra and a low overall K factor of -3.6 dB. VTV-Urban Canyon Oncoming has a larger overall K factor of 3 dB, a smaller offset, and a somewhat smaller Doppler width.

RTV-Suburban Street and RTV-Expressway have similar PERs. Because only one terminal is moving, these models have roughly half the Doppler offsets. RTV-Suburban Street has a moderate overall K factor of 2.1 dB, but is one of the two models with the largest maximum excess delay of 700ns. RTV-Expressway has a larger overall K factor of 4.3dB, but a maximum excess delay of only 401ns.

VTV Expressway Same Direction has a moderate overall K factor of 3.3 dB and wide (but low power) Doppler spectra, but it has a zero Doppler offset.

The most benign channel, RTV Urban Canyon, has the largest overall K factor at 6.7dB. It has a maximum delay of 501ns, although the last four taps are relatively weak.

V. CONCLUSION

This report has presented six models, suitable for simulation on standard RF channel emulators, representing three VTV and three RTV environments measured in the Atlanta, Georgia metropolitan area. The models were ranked in terms of PER measured at -79 dBm with 1000-byte PSDUs, and the VTV Expressway without Wall channel had the highest measured PER. Therefore, this is the model we recommend for the certification test, because if equipment passes the certification test with this channel it is likely that it will pass the other channels as well.

ACKNOWLEDGMENT

The authors gratefully acknowledge the support for this work provided by ARINC, Inc., Contract No. DTFH6199-C-00018.

TABLE II
VTV CHANNEL MODELS FOR THE SIX SCENARIOS¹

TAP NO.	PATH NO.	TAP POWER (dB)	RELATIVE PATH LOSS (dB)	DELAY VALUE (ns)	RICIAN K (dB)	FREQUENCY SHIFT (Hz)	FADING DOPPLER (Hz)	LOS DOPPLER (Hz)	MODULATION	FADING SPECTRAL SHAPE
1	1	0.0	[0.0, -1.8, 0.0, 0.0, 0.0, -1.4]	0	[-1.6, 7.5, -5.3, 4.0, 3.3, 23.8]	[1451, 574, 769, 1145, 648, -55]	[60, 165, 70, 284, 152, 1407]	[1452, 654, 770, 1263, 635, -60]	Rician	Round
1	2	0.0	[-24.9, -30.5, -36.4, -17.6, -21.5, -5.6]	1	n/a	[884, -97, -22, 833, 171, -20]	[858, 543, 600, 824, 823, 84]	n/a	Rayleigh	[R, C3, R, R, R, R]
[1, 1, 1, 2, 2, 2]	3	[0.0, 0.0, 0.0, -10.0, -9.3, -11.2]	[-25.5, -25.1, -30.0, -12.9, -11.8, -14.2]	[2, 2, 2, 100, 100, 100]	[n/a, n/a, n/a, n/a, n/a, 5.7]	[1005, -89, 535, 707, 582, -56]	[486, 478, 376, 871, 249, 1345]	[n/a, n/a, n/a, n/a, n/a, 40]	[Y, Y, Y, Y, Y, I]	[R, C3, R, R, R, C3]
2	4	[-6.3, -11.5, -9.3, -10.0, -9.3, -11.2]	[-13.1, -27.1, -12.3, -19.0, -18.8, -14.2]	[100, 100, 100, 101, 101, 101]	n/a	[761, -549, 754, 918, -119, 0]	[655, 174, 117, 286, 515, 70]	n/a	Rayleigh	[C3, R, R, C6, C3, R]
[2, 2, 2, 2, 3, 3]	5	[-6.3, -11.5, -9.3, -10.0, -14.0, -19.0]	[-7.5, -17.7, -21.7, -36.4, -17.6, -19.0]	[101, 101, 101, 102, 200, 200]	n/a	[1445, 559, 548, -250, 527, -87]	[56, 196, 424, 936, 223, 358]	n/a	Rayleigh	[R, R, R, F, R, C6]
[3, 2, 2, 3, 3, 4]	6	[-25.1, -11.5, -9.3, -17.8, -14.0, -21.9]	[-28.9, -19.5, -24.9, -25.8, -19.9, -21.9]	[200, 102, 102, 200, 201, 300]	n/a	[819, 115, -134, 21, 62, -139]	[823, 757, 530, 166, 802, 1397]	n/a	Rayleigh	[C3, C6, F, R, F, C3]
[3, 3, 3, 3, 4, 5]	7	[-25.1, -19.0, -20.3, -17.8, -18.0, -25.3]	[-29.3, -17.6, -24.3, -21.2, -23.0, -27.9]	[201, 200, 200, 201, 300, 400]	n/a	[1466, 610, 761, 677, 497, 60]	[75, 258, 104, 726, 396, 522]	n/a	Rayleigh	[F, C6, R, F, C6, C6]
[3, 3, 3, 3, 4, 5]	8	[-25.1, -19.0, -20.3, -17.8, -18.0, -25.3]	[-35.6, -19.9, -25.4, -31.6, -20.8, -30.8]	[202, 201, 201, 202, 301, 401]	n/a	[124, 72, 88, -188, 87, -561]	[99, 929, 813, 538, 851, 997]	n/a	Rayleigh	[R, F, C3, R, R, C3]
[4, 4, 4, 4, 5, 6]	9	[-22.7, -25.6, -21.3, -21.1, -19.4, -24.4]	[-25.7, -23.3, -26.8, -28.2, -19.4, -24.4]	[300, 300, 300, 300, 400, 500]	n/a	[1437, 183, 37, 538, 43, 50]	[110, 653, 802, 908, 747, 529]	n/a	Rayleigh	[F, C6, C6, R, R, R]
[4, 4, 4, 4, 6, 7]	10	[-22.7, -25.6, -21.3, -21.1, -24.9, -28.0]	[-34.4, -20.6, -28.5, -28.3, -24.9, -28.0]	[301, 301, 301, 301, 500, 600]	n/a	[552, 103, 752, 41, 114, 13]	[639, 994, 91, 183, 742, 1572]	n/a	Rayleigh	[C3, R, R, R, C6, R]
[4, 5, 5, 5, 7, 8]	11	[-22.7, -28.1, -28.8, -26.3, -27.5, -26.1]	[-27.4, -29.8, -31.2, -28.5, -27.5, -31.5]	[302, 500, 400, 400, 600, 700]	n/a	[868, 720, 16, 674, 38, -6]	[858, 220, 807, 723, 746, 1562]	n/a	Rayleigh	[C6, F, C6, C6, C3, C6]
[n/a, 5, 5, 5, 8, 8]	12	[n/a, -28.1, -28.8, -26.3, -29.8, -26.1]	[n/a, -28.0, -41.8, -35.5, -29.8, -28.1]	[n/a, 501, 401, 401, 700, 701]	n/a	[n/a, -20, -755, -78, 8, 4]	[n/a, 871, 329, 260, 743, 81]	n/a	Rayleigh	[n/a, F, R, R, C3, R]

Notes:

- Data vector format:
[VTV-Expressway Oncoming, RTV-Expressway, RTV-Suburban Street, RTV-Urban Canyon, VTV-Urban Canyon Oncoming, VTV-Express. Same Direction With Wall]
- n/a means not-applicable
- Spectral shapes are Flat (F), Round (R), Classic 3 dB (C3), and Classic 6 dB (C6)
- Modulation is Rician (I) and Rayleigh (Y)

REFERENCES

- IEEE P802.11pTM/D2.01, "Standard for Wireless Local Area Networks providing wireless communications while in vehicular environment."
- C. S. Patel, G. L. Stüber, and T. G. Pratt, "Simulation of Rayleigh faded mobile-to-mobile communication channels," in Proc. of IEEE Vehicular Technology Conf., vol. 1, pp. 163-167, October 2003.
- F. Vatalaro and A. Forcella, "Doppler spectrum in mobile-to-mobile communications in the presence of three-dimensional multipath scattering," IEEE Trans. on Vehic. Tech., vol. 46, no. 1, pp. 213-219, 1997.
- J. Maurer, T. Fügen and W. Wiesbeck, "Narrow-band measurement and analysis of the inter-vehicle transmission channel at 5.2 GHz," in Proc. of IEEE Vehicular Technology Conf., vol. 3, pp. 1274-1278, 2002.
- X. Zhao, J. Kivinen, P. Vainikainen, and K. Skog, "Characterization of Doppler spectra for mobile communications at 5.3 GHz," IEEE Trans. Vehicular Technology, vol. 52, no. 1, pp. 14-23, 2003.
- Matolak, D.W.; Indranil Sen; Wenhui Xiong; Yaskoff, N.T., "5 GHZ Wireless Channel Characterization for Vehicle to Vehicle Communications," IEEE Military Communications Conference, 2005, Page(s):1 - 7, 17-20 Oct. 2005.
- G. Acosta, K. Tokuda, and M. A. Ingram, "Measured joint Doppler-delay power profiles for vehicle-to-vehicle communications at 2.4 GHz," in Proc. of IEEE Global Telecom. Conf., vol. 6, pp. 3813-3817, 2004.
- Guillermo Acosta and Mary Ann Ingram, "Model development for the wideband vehicle-to-vehicle 2.4 GHz channel," Proc. IEEE Wireless Communications & Networking Conference (WCNC 2006), Las Vegas, NV, 3-6 April 2006.
- G. Acosta-Marum and M.A. Ingram, "A BER-Based Partitioned Model for a 2.4 GHz Vehicle-to-Vehicle Expressway Channel," in International Journal on Wireless Personal Communication, July 2006.
- Spirent Communications SR5500 Wireless Channel Emulator Operations Manual. www.spirentcom.com
- G. Acosta-Marum and M.A. Ingram, "Doubly selective vehicle-to-vehicle channel measurements and modeling at 5.9 GHz," in Proc. Wireless Personal Multimedia Communications Conference (WPMC 2006).
- X. Cai and G.B. Giannakis, "Bounding performance and suppressing intercarrier interference in wireless mobile OFDM," IEEE Trans. Comm. Vol. 51, No. 12, December 2003.