

JULY 2006

doc.: IEEE 802.11-06/1017r1

WAVE Motion-Related Channel Model Development

Date: 2006-07-18

Authors:

Name	Company	Address	Phone	email
Mary Ann Ingram	Georgia Institute of Technology	School of ECE Atlanta, GA 30332-0250	404-894-0492	mai@ece.gatech.edu
Guillermo Acosta	Georgia Institute of Technology	School of ECE Atlanta, GA 30332-0250	404 297 7941	gacosta@gatech.edu

Notice: This document has been prepared to assist IEEE 802.11. It is offered as a basis for discussion and is not binding on the contributing individual(s) or organization(s). The material in this document is subject to change in form and content after further study. The contributor(s) reserve(s) the right to add, amend or withdraw material contained herein.

Release: The contributor grants a free, irrevocable license to the IEEE to incorporate material contained in this contribution, and any modifications thereof, in the creation of an IEEE Standards publication; to copyright in the IEEE's name any IEEE Standards publication even though it may include portions of this contribution; and at the IEEE's sole discretion to permit others to reproduce in whole or in part the resulting IEEE Standards publication. The contributor also acknowledges and accepts that this contribution may be made public by IEEE 802.11.

Patent Policy and Procedures: The contributor is familiar with the IEEE 802 Patent Policy and Procedures <<http://ieee802.org/guides/bylaws/sb-bylaws.pdf>>, including the statement "IEEE standards may include the known use of patent(s), including patent applications, provided the IEEE receives assurance from the patent holder or applicant with respect to patents essential for compliance with both mandatory and optional portions of the standard." Early disclosure to the Working Group of patent information that might be relevant to the standard is essential to reduce the possibility for delays in the development process and increase the likelihood that the draft publication will be approved for publication. Please notify the Chair <stuart.kerry@philips.com> as early as possible, in written or electronic form, if patented technology (or technology under patent application) might be incorporated into a draft standard being developed within the IEEE 802.11 Working Group. If you have questions, contact the IEEE Patent Committee Administrator at <patcom@ieee.org>.

Submission Slide 1 Mary Ann Ingram, Georgia Institute of Technology

JULY 2006

doc.: IEEE 802.11-06/1017r1

Abstract

A method to develop a commercial channel emulator model for a doubly selective vehicle-to-vehicle wireless channel is presented. The model was developed from measurements taken at 5.9 GHz in an expressway environment when the vehicles are traveling in the same direction. The probe waveform is a combination of a direct sequence spread spectrum (DSSS) waveform with an orthogonal frequency division multiplexing (OFDM) waveform with a chirp signal for pulse compression.

Submission Slide 2 Mary Ann Ingram, Georgia Institute of Technology

JULY 2006

doc.: IEEE 802.11-06/1017r1

Outline

- **Project Objective**
- **Measurement Description**
- **Channel Modeling**
- **Expressway Same Direction with Wall Model**
- **PER Testing**
- **Conclusions and Future Work**

Submission

Slide 3

Mary Ann Ingram, Georgia Institute of Technology

JULY 2006

doc.: IEEE 802.11-06/1017r1

Project Objective

- **Develop a channel model* for motion-related equipment certification test for 802.11p**
- **Base the model on measurements at 5.9GHz**
- **Demonstrate the test on a SPIRENT 5500 RF channel emulator**

* Previous and current modeling methods can be found in [1] and [2], respectively

Submission

Slide 4

Mary Ann Ingram, Georgia Institute of Technology

JULY 2006

doc.: IEEE 802.11-06/1017r1

Outline

- Project Objective
-  • Measurement Description
- Channel Modeling
- Expressway Same Direction with Wall Model
- PER Testing
- Conclusions and Future Work

Submission

Slide 5

Mary Ann Ingram, Georgia Institute of Technology

JULY 2006

doc.: IEEE 802.11-06/1017r1

Measurement Descriptions

- **Phase I – 2004**
 - Emphasis on sites with large delay spreads
 - 2.4 GHz with max range 300m (power limited)
 - 20 MHz bandwidth
- **Phase II – Spring 2006**
 - Emphasis on nominal LOS channels
 - 5.9 GHz with ranges up to 1 km
 - More scenarios, including roadside-to-vehicle
 - 10 MHz bandwidth

Submission

Slide 6

Mary Ann Ingram, Georgia Institute of Technology

JULY 2006

doc.: IEEE 802.11-06/1017r1

Phase II Sites

138 Takes (184 GBytes), each one containing 16 0.6 second segments for the following locations:

- **Urban Canyon – dense, tall buildings**
 - Oncoming
 - 1 Km, 15m, 100m, 300m to 400m
 - Same-direction
 - 1 Km, 100m
- **Suburban Expressway – moderately dense, low-story buildings**
 - Oncoming
 - 400m, no center wall.
 - Same-direction
 - 400m; with and without center wall
 - RTV
 - 400m
- **Suburban Surface Street – moderately dense, low-story buildings**
 - Oncoming
 - 300m, 400m
 - Same-direction
 - 100m; 400m
 - RTV
 - 100m, 1 Km

Submission

Slide 7

Mary Ann Ingram, Georgia Institute of Technology

JULY 2006

doc.: IEEE 802.11-06/1017r1

Expressway Same Direction Wall

- **The transmitter is in front approx. 400 m ahead**
- **Moderate traffic**
- **Notice the truck blocking the LOS**
- **Notice the overpass**



Submission

Slide 8

Mary Ann Ingram, Georgia Institute of Technology

JULY 2006

doc.: IEEE 802.11-06/1017r1

Expressway Oncoming

- Very low traffic
- No buildings
- Both vehicles on right lane



Submission

Slide 9

Mary Ann Ingram, Georgia Institute of Technology

JULY 2006

doc.: IEEE 802.11-06/1017r1

Sounding Waveform

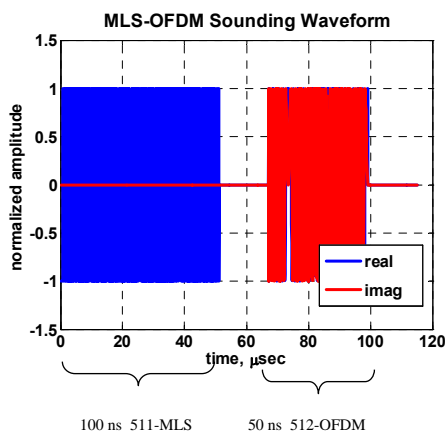

Maximum Path Length-MLS	15.33 km
Maximum Path Length-OFDM	7.68 km
T_c	50 ns
3 dB BW	20 MHz
T_{rp}	115.1 μs
Maximum Doppler Frequency	± 4.344 kHz

Submission

Slide 10

Mary Ann Ingram, Georgia Institute of Technology

JULY 2006 **doc.: IEEE 802.11-06/1017r1**

Phase II Transmitter

Submission Slide 11 Mary Ann Ingram, Georgia Institute of Technology

JULY 2006 **doc.: IEEE 802.11-06/1017r1**

Phase II Receiver

Built a down-converting front end

RF BW	40 MHz
IF	1 GHz
ADC	12 bit 80 MHz
Data Rate	20x10⁶ complex samples/s

Submission Slide 12 Mary Ann Ingram, Georgia Institute of Technology

JULY 2006

doc.: IEEE 802.11-06/1017r1

Signal Processing

- **We operate on the recorded complex baseband data as follows:**

- Correlate the first ten repetitions of the combined waveform with the MLS sequence to find a suitable starting point
- Separate MLS and OFDM parts
- For the MLS part, we first use a Mueller-Mueller timing algorithm to obtain the 100 ns samples and then pass it through the correlator to create the IRs
- For the OFDM part,
 - We remove the cyclic prefix and take the FFT
 - We then divide the received frequency response by the system's frequency response
 - We take the IFFT to obtain the IR

Submission

Slide 13

Mary Ann Ingram, Georgia Institute of Technology

JULY 2006

doc.: IEEE 802.11-06/1017r1

Outline

- **Project Objective**
- **Measurement Description**
- **Channel Modeling**
 - Constraints
 - Tap delays and powers
 - Tap K factors
 - Doppler spectrum modeling
- **Expressway Same Direction with Wall Model**
- **PER Testing**
- **Conclusions and Future Work**

Submission

Slide 14

Mary Ann Ingram, Georgia Institute of Technology

JULY 2006

doc.: IEEE 802.11-06/1017r1

Channel Modeling Constraints

- **Constraints of the commercial RF channel emulator**
 - Limited number of paths
 - Limited selection of Doppler spectrum shapes
- **Constraints of the measurement system**
 - 100ns delay resolution
- **Important that the model deliver 802.11p link performance similar to recorded channel**
 - Will emphasize inter-carrier interference effects from Doppler spread

Submission

Slide 15

Mary Ann Ingram, Georgia Institute of Technology

JULY 2006

doc.: IEEE 802.11-06/1017r1

Outline

- **Project Objective**
- **Measurement Description**
- **Channel Modeling**
 - Constraints
 -  – Tap delays and powers
 - Tap K factors
 - Doppler spectrum modeling
- **Expressway Same Direction with Wall Model**
- **PER Testing**
- **Conclusions and Future Work**

Submission

Slide 16

Mary Ann Ingram, Georgia Institute of Technology

JULY 2006

doc.: IEEE 802.11-06/1017r1

Tap Power and Delay Identification

- Remove long-term trend (path loss)
- Obtain power delay profile (PDP) for each 0.6 sec segment by averaging the magnitudes squared of the impulse responses (IRs)
- Apply 30 dB threshold
- Average segment PDPs over the scenario to get a scenario power delay profile (PDP)
- Apply the 30 dB threshold again
- The non-zero bins of the scenario PDP will correspond to the “significant taps” of the model

Submission

Slide 17

Mary Ann Ingram, Georgia Institute of Technology

JULY 2006

doc.: IEEE 802.11-06/1017r1

Segment PDPs for Expressway, Same-Direction

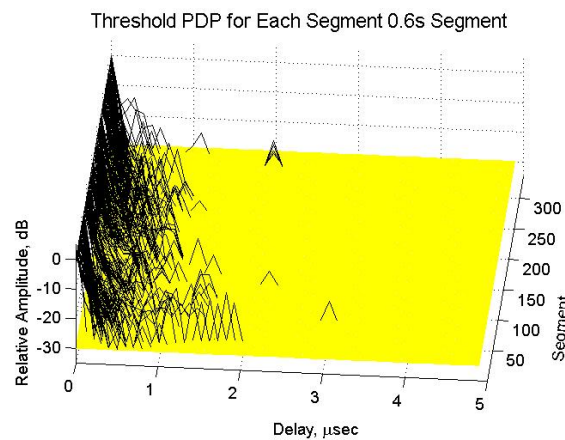

Submission

Slide 18

Mary Ann Ingram, Georgia Institute of Technology

JULY 2006

doc.: IEEE 802.11-06/1017r1

Scenario PDP for Expressway Same-Direction

- The delay resolution is 100 ns
- The significant bins for the model are the points > -30 dB
- Therefore, there are eight taps in this model

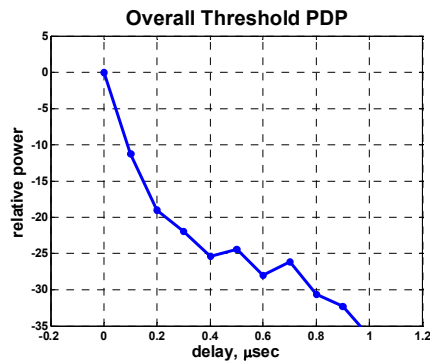

Submission

Slide 19

Mary Ann Ingram, Georgia Institute of Technology

JULY 2006

doc.: IEEE 802.11-06/1017r1

Outline

- Project Objective
- Measurement Description
- Channel Modeling
 - Constraints
 - Tap delays and powers
 - ➔ - Tap K factors
 - Doppler spectrum modeling
- Expressway Same Direction with Wall Model
- PER Testing
- Conclusions and Future Work

Submission

Slide 20

Mary Ann Ingram, Georgia Institute of Technology

JULY 2006

doc.: IEEE 802.11-06/1017r1

K Factor Identification

$$\text{K Factor} = \frac{\text{Power of Deterministic or Constant-Envelope Part}}{\text{Power of Random or Diffuse-Scattering Part}}$$

- Apply the Moment Method [3] to identify these powers for each tap in each segment
- Obtain an average deterministic power per tap for the scenario
- Obtain an average random power per tap for the scenario
- “Scenario K-Factors” are the ratio of these powers for each tap

Submission

Slide 21

Mary Ann Ingram, Georgia Institute of Technology

JULY 2006

doc.: IEEE 802.11-06/1017r1

Segment K Factors vs. Tap No. (21 Takes; 16 Segments per Take) Expressway, same-direction, wall

Scenario K Factor vs. Tap No.

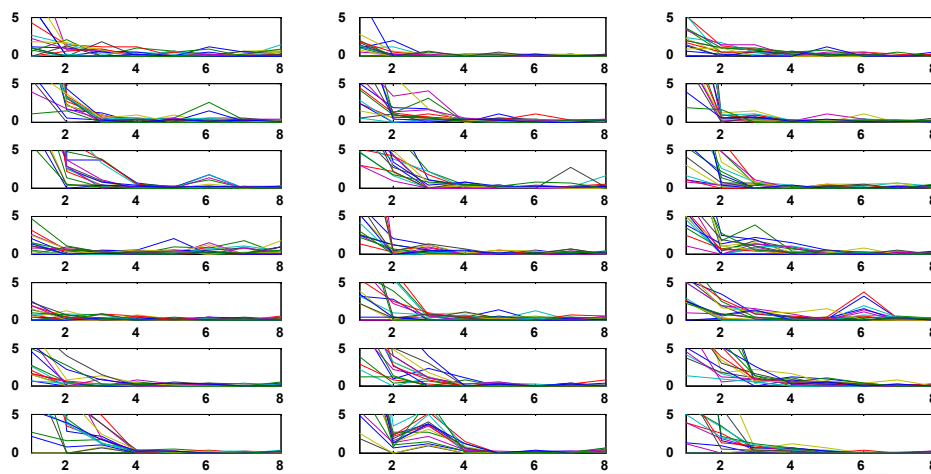
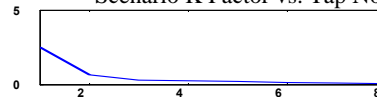

Submission

Slide 22

Mary Ann Ingram, Georgia Institute of Technology

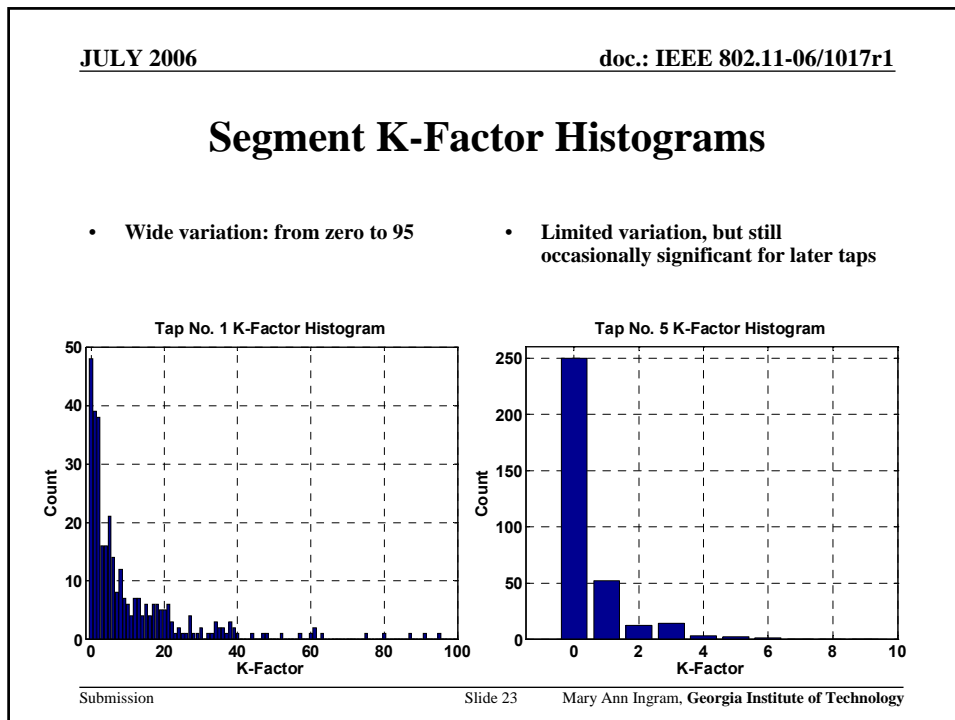

- JULY 2006 doc.: IEEE 802.11-06/1017r1
- ### Outline
- **Project Objective**
 - **Measurement Description**
 - **Channel Modeling**
 - Constraints
 - Tap delays and powers
 - Tap K factors
 - ➔ - Doppler spectrum modeling
 - **Expressway Same Direction with Wall Model**
 - **PER Testing**
 - **Conclusions and Future Work**
- Submission Slide 24 Mary Ann Ingram, Georgia Institute of Technology

JULY 2006

doc.: IEEE 802.11-06/1017r1

Spectrum Modeling Approach

- **Separate the deterministic part of the spectrum from the random part, for each tap and segment**
 - Two methods are considered:
 - Level method (used for the results shown)
 - Hole method
- **Average the random spectra over the segments**
- **Fit channel emulator shapes to the averaged random spectra**
 - Decide if one or two shapes per tap are necessary
- **Insert deterministic part**
- **Scale all frequencies to be consistent with specified vehicle speed**

Submission

Slide 25

Mary Ann Ingram, Georgia Institute of Technology

JULY 2006

doc.: IEEE 802.11-06/1017r1

Example of Level Approach

- **First bin, for well-separated vehicles traveling in the same direction on the expressway**

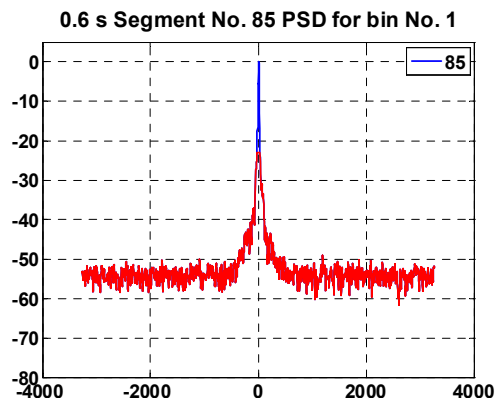

Submission

Slide 26

Mary Ann Ingram, Georgia Institute of Technology

JULY 2006 doc.: IEEE 802.11-06/1017r1

Random Part Averaging

- The base or “red” parts of the spectra are averaged across segments for a given scenario and bin

Averaging is
across segments

Submission Slide 27 Mary Ann Ingram, Georgia Institute of Technology

JULY 2006 doc.: IEEE 802.11-06/1017r1

Result of Averaging

Tap 1

Tap 2

Submission Slide 28 Mary Ann Ingram, Georgia Institute of Technology

JULY 2006

doc.: IEEE 802.11-06/1017r1

Problem with Level Approach

- Sometimes it clips more than one line

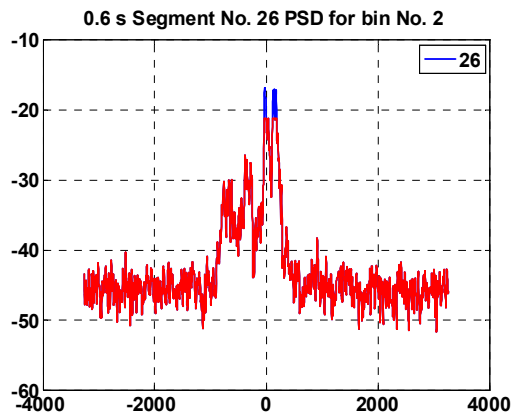

Submission

Slide 29

Mary Ann Ingram, Georgia Institute of Technology

JULY 2006

doc.: IEEE 802.11-06/1017r1

“Hole” Approach to Spectral Line Removal

- Remove an area of the spectrum, centered at the peak, that corresponds to the power of the Rician (or constant envelope) component

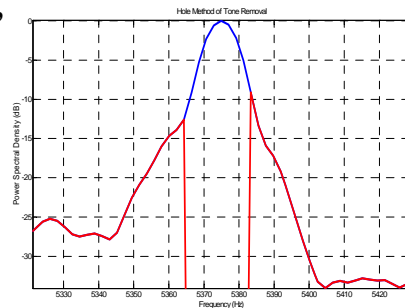

Submission

Slide 30

Mary Ann Ingram, Georgia Institute of Technology

JULY 2006 doc.: IEEE 802.11-06/1017r1

Comparing Averages for Level and Hole Methods

- Tap 1, Expressway, same direction with wall

Level Method

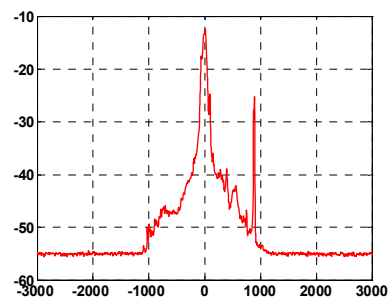

Hole Method

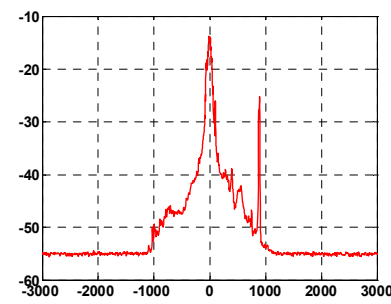

Submission Slide 31 Mary Ann Ingram, Georgia Institute of Technology

JULY 2006 doc.: IEEE 802.11-06/1017r1

Channel Emulator Doppler Spectrum Shapes

- Two or more paths with the same delay can be used to construct a “composite spectrum”

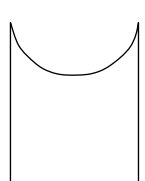

Classical 6 dB

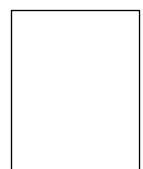

Flat

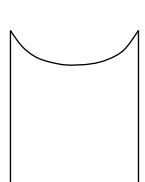

Classical 6 dB

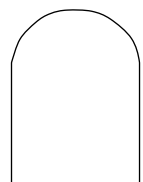

Rounded

Submission Slide 32 Mary Ann Ingram, Georgia Institute of Technology

Shape-Fitting Cost Function

- Even with two shapes, parts of the measured Doppler spectrum will not be well fit
- Intercarrier interference (ICI) is the primary channel impairment for mobile OFDM [4], so we use the Genetic Algorithm [9] to try to make

$$Model\ ICI \approx Measured\ channel\ ICI$$

- Specifically, we minimize [2]

$$\int |\phi(f) - \phi'(f)| f^2 df$$

Measured Doppler spectrum Model Doppler spectrum Higher Doppler frequencies are emphasized

Example: One Shape per Tap Fitting

Tap 6

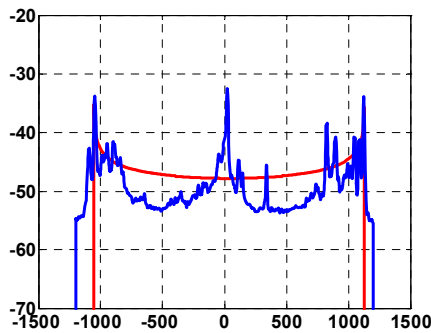

Tap 7

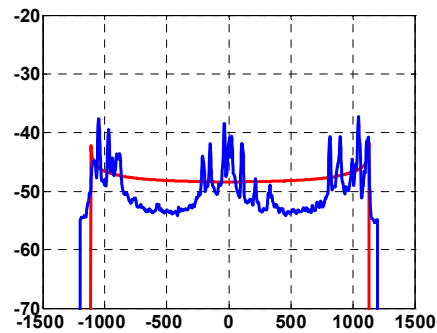

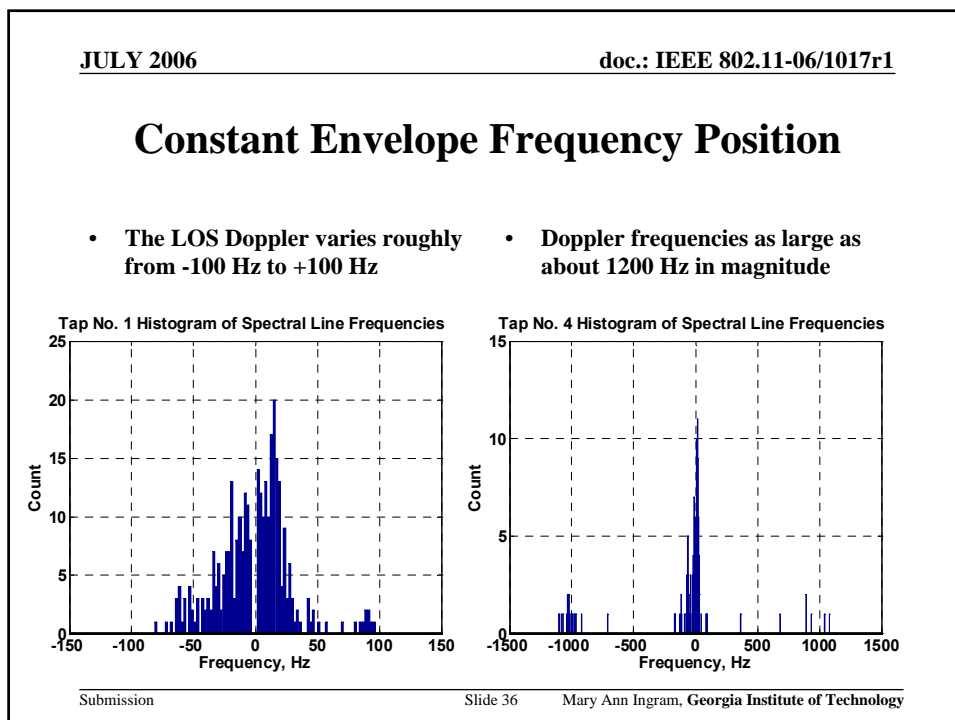
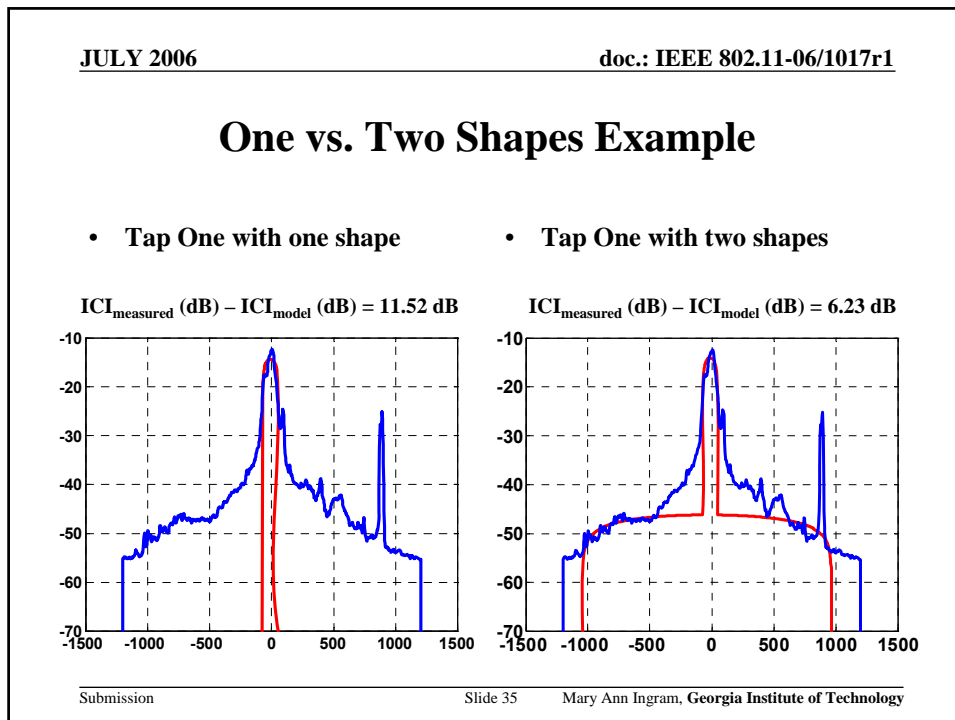

JULY 2006

doc.: IEEE 802.11-06/1017r1

Normalized Correlation Between Spectral Line Frequencies of Taps- Expressway, same-direction

0	0,25344	0,045529	0,12437	-0,010904	-0,01067	-0,15527	0,060848
0	0	0,19712	0,021794	-0,083639	-0,004934	-0,088806	0,14189
0	0	0	0,33887	0,052879	0,034775	-0,065462	-0,073024
0	0	0	0	0,27789	0,02787	-0,007087	0,029151
0	0	0	0	0	0,27233	0,12267	0,14823
0	0	0	0	0	0	0,36123	0,30059
0	0	0	0	0	0	0	0,42088
0	0	0	0	0	0	0	0

Very low correlation is exhibited between the frequencies of the adjacent tap's spectral lines

Submission

Slide 37

Mary Ann Ingram, Georgia Institute of Technology

JULY 2006

doc.: IEEE 802.11-06/1017r1

Spectral Line Location

- Selection of tap spectral line for the model, Taps 1 and 2, was a somewhat arbitrary choice, but based on the histogram
- Low correlation meant that we could choose any frequencies for each tap that were within the range indicated by the histograms

Submission

Slide 38

Mary Ann Ingram, Georgia Institute of Technology

JULY 2006

doc.: IEEE 802.11-06/1017r1

Outline

- Project Objective
- Measurement Description
- Channel Modeling
- • Expressway Same Direction with Wall Model
- PER Testing
- Conclusions and Future Work

Submission

Slide 39

Mary Ann Ingram, Georgia Institute of Technology

JULY 2006

doc.: IEEE 802.11-06/1017r1

Expressway Same Direction Model

Tap No.	Path No.	Tap Power (dB)	Relative Path Loss (dB)	Delay Value (ns)	Rician K (dB)	Freq. Shift (Hz)	Fading Doppler (Hz)	LOS Doppler (Hz)	Modulation	Fad. Spec. Shape
1	1	0.0	-1.4	0	23.8	-55	1407	-60	Rician	Round
1	2		-5.6	1	n/a	-20	84	n/a	Rayleigh	Round
2	3	-11.2	-14.2	100	5.7	-56	1345	+40	Rician	Classic 3 dB
2	4	0	-14.2	101	n/a	0	70	n/a	Rayleigh	Round
3	5	-19.0	-19.0	200	n/a	-87	1358	n/a	Rayleigh	Classic 6 dB
4	6	-21.9	-21.9	300	n/a	-139	1397	n/a	Rayleigh	Classic 3 dB
5	7	-25.3	-27.9	400	n/a	60	1522	n/a	Rayleigh	Classic 6 dB
5	8		-30.8	401	n/a	-561	997	n/a	Rayleigh	Classic 3 dB
6	9	-24.4	-24.4	500	n/a	50	1529	n/a	Rayleigh	Round
7	10	-28.0	-28.0	600	n/a	13	1572	n/a	Rayleigh	Round
8	11	-26.1	-31.5	700	n/a	-6	1562	n/a	Rayleigh	Classic 6 dB
8	12		-28.1	701	n/a	4	81	n/a	Rayleigh	Round

Submission

Slide 40

Mary Ann Ingram, Georgia Institute of Technology

JULY 2006

doc.: IEEE 802.11-06/1017r1

Expressway Same Direction Model Notes

1. Taps 1, 2, 5 and 8 have composite spectra. Each tap comprises two paths. The first two taps each have Rician and Rayleigh paths. The overall K factor is 4.0 dB for Tap 1 and -1.8 dB for Tap 2. Tap 8 comprises two Rayleigh paths. All paths associated with a composite Doppler spectrum have excess delays differing by 1ns. This is to ensure that the channel emulator creates them as separate paths. Because of its limited bandwidth, the unit under test will perceive two paths that differ in delay by only 1 ns as having essentially the same delay.
2. "n/a" means "not applicable."
3. This channel is normalized so that the first tap power is 0 dB.
4. The parameters are named according to the Spirent SR5500 TestKit control software.
5. The SR5500 parameters LOS AOA and LOS Doppler are interdependent.
6. The SR5500 parameters Fading Doppler and Fading Doppler Vel. are interdependent.

Submission

Slide 41

Mary Ann Ingram, Georgia Institute of Technology

JULY 2006

doc.: IEEE 802.11-06/1017r1

Outline

- Project Objective
- Measurement Description
- Channel Modeling
- Expressway Same Direction with Wall Model
-  PER Testing
 - Sources of hardware and software
 - Test setup description
 - PER results
- Conclusions and Future Work

Submission

Slide 42

Mary Ann Ingram, Georgia Institute of Technology

JULY 2006

doc.: IEEE 802.11-06/1017r1

Sources of Hardware and Software

- Channel emulator purchased on the contract
- OBU and RSU prototypes supplied by Transcore
- Network interface programs provided by Filip Weytjens of Transcore
- C++ TX and RX PER measurement programs written at Georgia Tech using the ping application with the IPv6 protocol

Submission

Slide 43

Mary Ann Ingram, Georgia Institute of Technology

JULY 2006

doc.: IEEE 802.11-06/1017r1

PER Setup Diagram

- RSU = TX and OBU = RX, but these can be reversed

- Circulator D3C4080 allows signal flows only as shown:

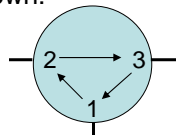

- Isolator D314084 allows signals to flow only one way

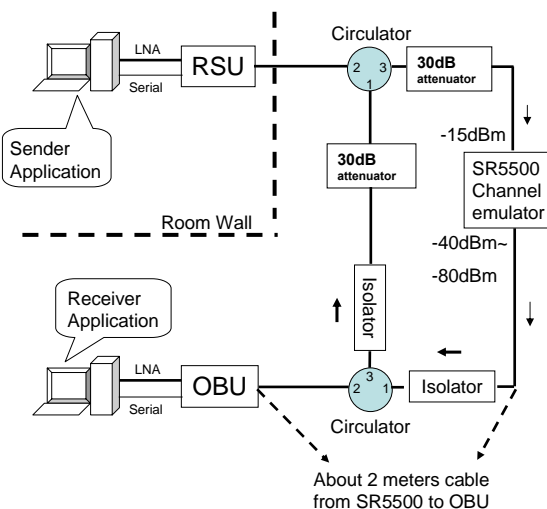

Submission

Slide 44

Mary Ann Ingram, Georgia Institute of Technology

JULY 2006

doc.: IEEE 802.11-06/1017r1

TX/RX Isolation in the Test Setup

- Each unit placed in a closed cardboard box, lined with absorber and wrapped in aluminum foil
- Placed in different rooms with door closed during tests

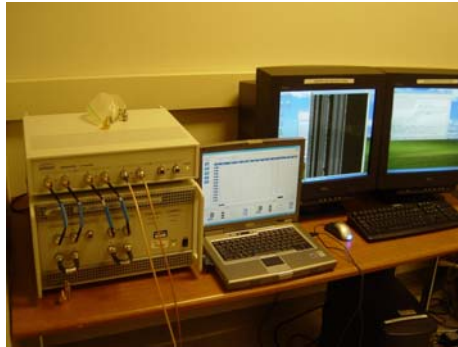

SR5500 Channel Emulator

Submission



Transmitter and Receiver units

Slide 45

Mary Ann Ingram, Georgia Institute of Technology

JULY 2006

doc.: IEEE 802.11-06/1017r1

Setting the IPv6 Payload Length for a 1000-Byte PSDU

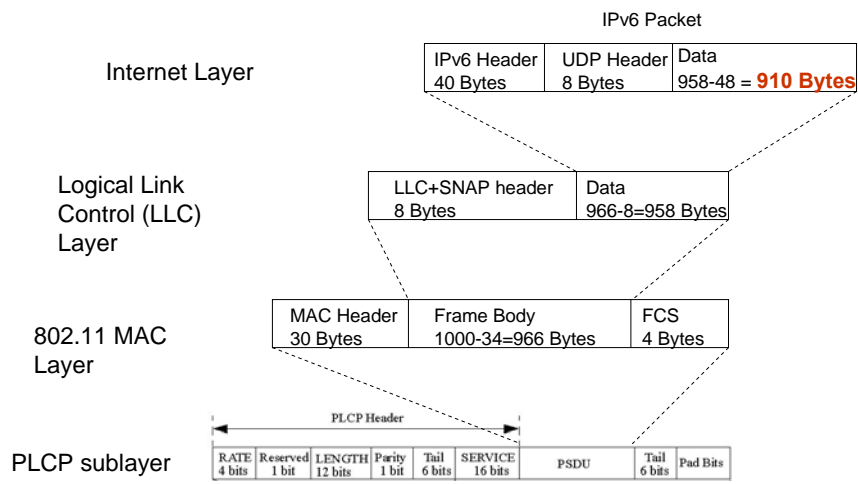

Submission

Slide 46

Mary Ann Ingram, Georgia Institute of Technology

JULY 2006

doc.: IEEE 802.11-06/1017r1

PER Test Parameters

- **Network interface**
 - TX power: highest setting (~ 15 dBm)
 - Data rate: 6 Mbps
 - Channel: 5.87 GHz
- **Sending Application**
 - Packet size: 910 or 210 Bytes (IPv6 payload)
 - Packet interval: 15 ms
 - Maximum number of packets: 10K to 100K

Submission

Slide 47

Mary Ann Ingram, Georgia Institute of Technology

JULY 2006

doc.: IEEE 802.11-06/1017r1

Cumulative PER Results for the 1000-Byte PSDU

- 15 ms packet transmission rate is only 66.7 packets/sec; 5 seconds is only 333 packets
- Higher transmission rate caused buffer problems
- Full model gives essentially PER = 0% for -79 dBm and higher
- Non-LOS case still less than 10% at -75 dBm

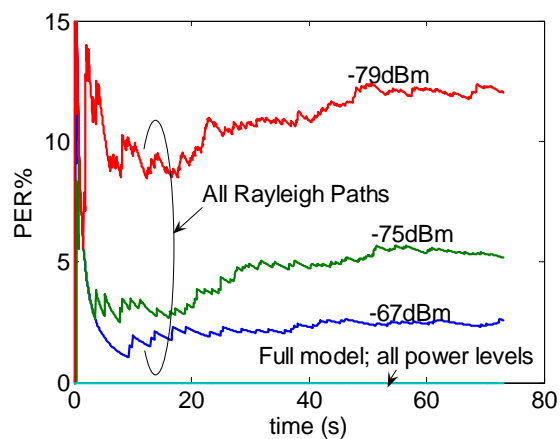

Submission

Slide 48

Mary Ann Ingram, Georgia Institute of Technology

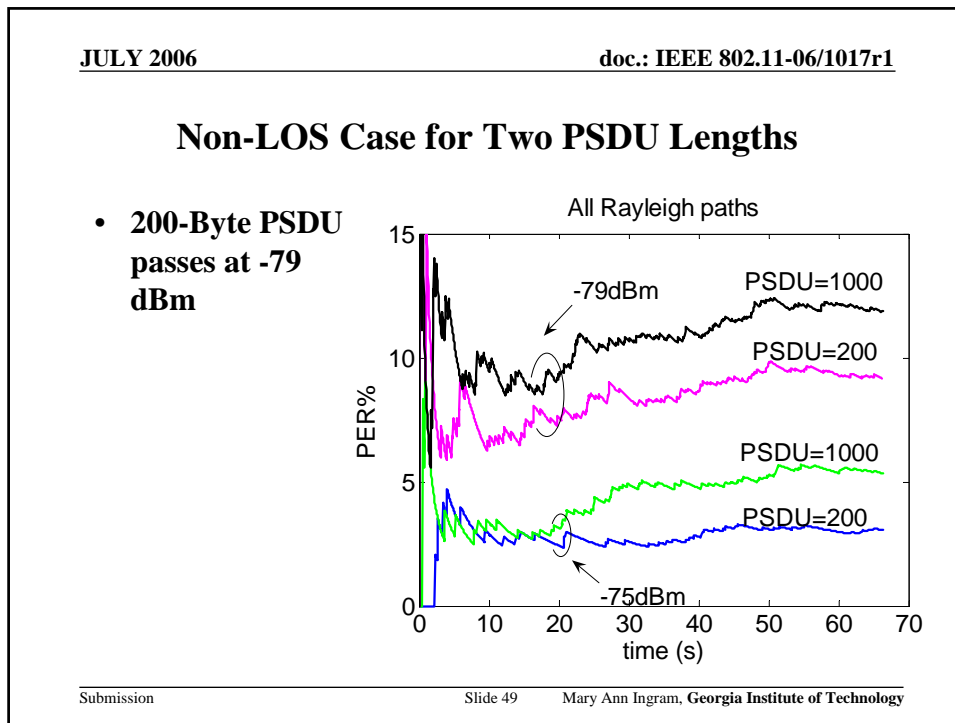

- JULY 2006 doc.: IEEE 802.11-06/1017r1
- ### Outline
- Project Objective
 - Measurement Description
 - Channel Modeling
 - Expressway Same Direction with Wall Model
 - PER Testing
 - ➔ • Conclusions and Future Work
- Submission Slide 50 Mary Ann Ingram, Georgia Institute of Technology

JULY 2006

doc.: IEEE 802.11-06/1017r1

Conclusions

- An 8-tap, non-separable model was produced for the expressway, same-direction, with wall scenario
- DSSS was preferred for PDP estimation, while OFDM (using DSSS for time-synchronization) was preferred for Doppler estimation
- Limited model degrees of freedom led to a model-fitting cost function based on ICI difference
- Some taps clearly require at least two paths to avoid excessive ICI difference
- PER measured with the prototypes and the full channel emulator model for 1000 Byte PSDU at -79 dBm was essentially 0%
- Removal of the LOS increased the PER, but at -75 dBm, it was still below 10%
- 5 seconds is not enough for a statistically significant PER measurement if the packet transmission period is only 15 ms

Submission

Slide 51

Mary Ann Ingram, Georgia Institute of Technology

JULY 2006

doc.: IEEE 802.11-06/1017r1

Future Plans

- Process four or five more scenarios and summarize the results in a journal article
- Develop dynamic models, preferably dynamic (e.g. Markov chain) FER models, suitable for network analysis (NSF proposal submitted)
- Investigate improved methods for K factor, PDP and Doppler estimation from the OFDM probe waveform
- Measure and process 2X2 MIMO at 2.4GHz

Submission

Slide 52

Mary Ann Ingram, Georgia Institute of Technology

JULY 2006

doc.: IEEE 802.11-06/1017r1

References

1. G. Acosta-Marum and M.A. Ingram, "A BER-based partitioned model for a 2.4 GHz vehicle-to-vehicle expressway channel," in International Journal on Wireless Personal Communication, July 2006.
2. G. Acosta-Marum and M.A. Ingram, "Doubly selective vehicle-to-vehicle channel measurements and modeling at 5.9 GHz," to appear in Proc. Wireless Personal Multimedia Communications Conference (WPMC 2006).
3. L. J. Greenstein, D. G. Michelson, and V. Erceg, "Moment-method estimation of the Ricean K -factor," in *IEEE Communications Letters*, vol. 3, No. 6, pp. 175-176, June 1999.
4. X. Cai and G.B. Giannakis, "Bounding performance and suppressing intercarrier interference in wireless mobile OFDM," *IEEE Trans. Comm.* Vol. 51, No. 12, December 2003.
5. <http://ideas.repec.org/c/cod/matlab/ga.html>

Submission

Slide 53

Mary Ann Ingram, Georgia Institute of Technology

JULY 2006

doc.: IEEE 802.11-06/1017r1

Extra Slides

Submission

Slide 54

Mary Ann Ingram, Georgia Institute of Technology

JULY 2006 **doc.: IEEE 802.11-06/1017r1**

Phase I Transmitter

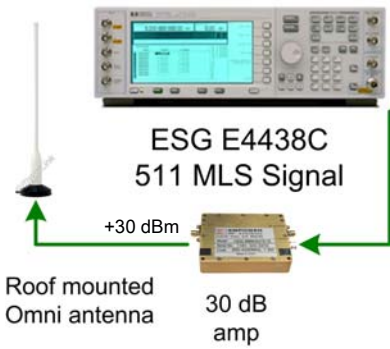

Length MLS	511
T_c	50 ns
3 dB BW	20 MHz
T_{rp}	25.5 μs
Maximum Path Length	7.65 km
Maximum Doppler Frequency	19.5 kHz

Submission Slide 55 Mary Ann Ingram, Georgia Institute of Technology

JULY 2006 **doc.: IEEE 802.11-06/1017r1**

Phase I Receiver

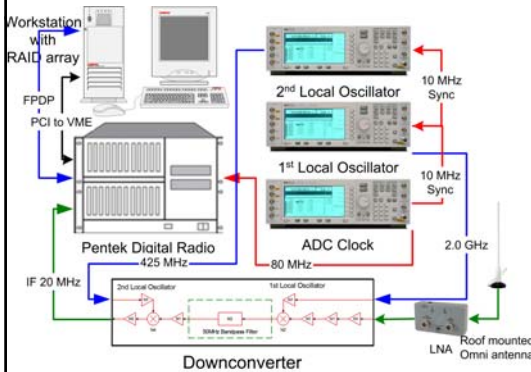

1st IF	445 MHz
2nd IF	20 MHz
IF Filter BW	46 MHz
ADC	12 bit 80 MHz
Data Rate	20x10⁶ complex samples/s
Recording Speed	80 Mbytes/s

Submission Slide 56 Mary Ann Ingram, Georgia Institute of Technology

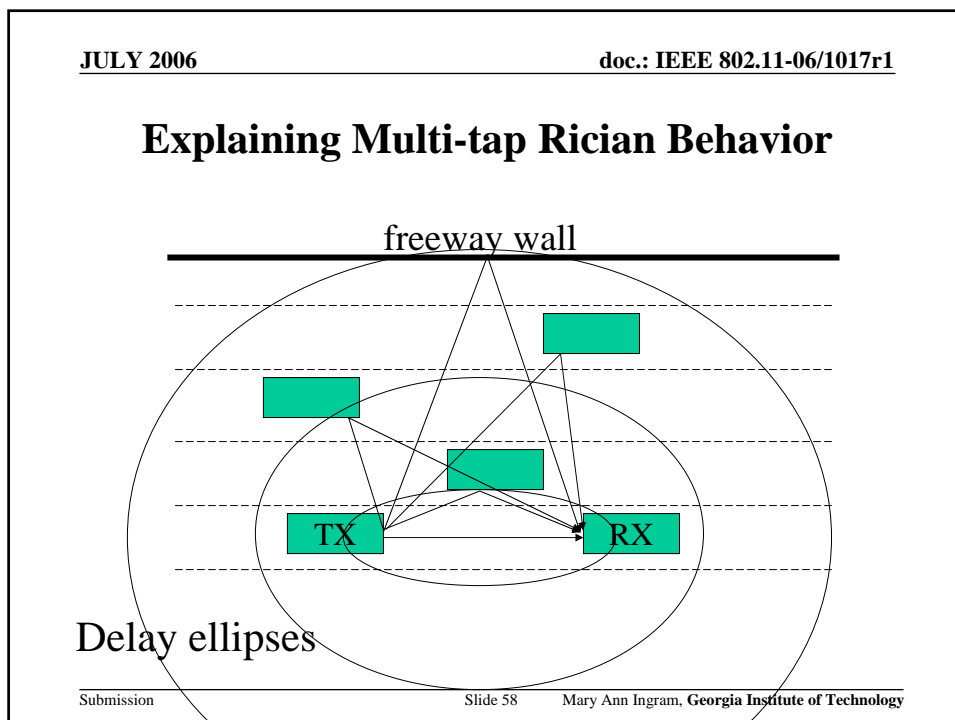
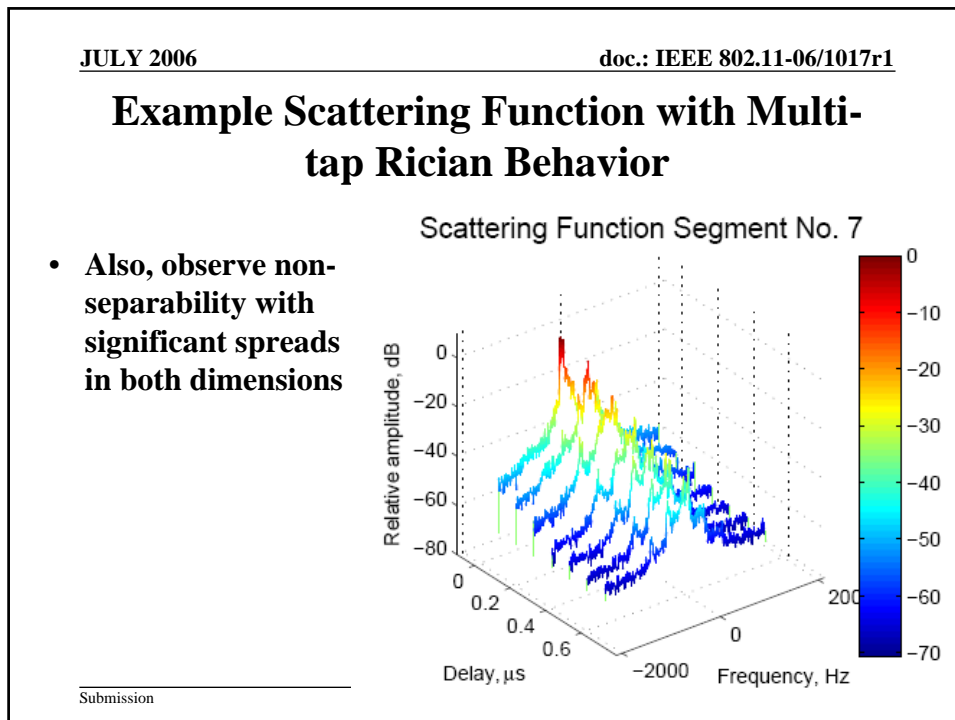

JULY 2006

doc.: IEEE 802.11-06/1017r1

Example 2 of Level Approach

- Passing vehicles on same expressway
- Broad peak is result of Welch's method on a moving spectral line

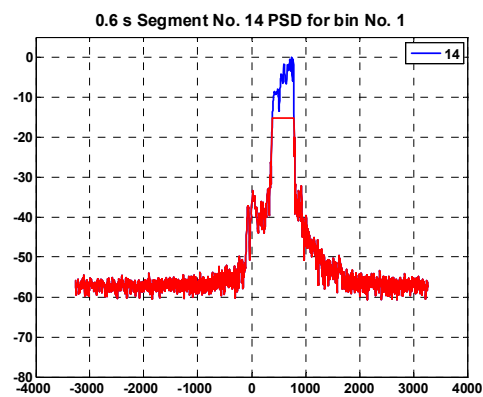

Submission

Slide 59

Mary Ann Ingram, Georgia Institute of Technology