

MR-MINI-LEVEL-SHIFTER™ Mini +5V ⇔ +3.3V LEVEL SHIFTER
User Manual

GRAVITECH.US

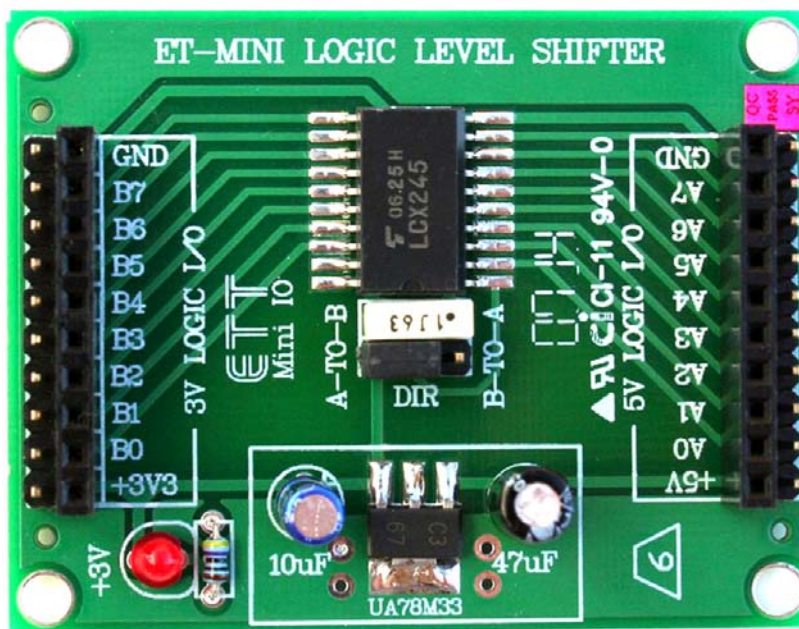

uResearch

GRAVITECH GROUP

Copyright © 2007 MicroResearch
GRAVITECH GROUP WWW.GRAVITECH.US

MR-MINI-LEVEL-SHIFTER™ Mini +5V ⇔ +3.3V LEVEL SHIFTER User Manual

Description

The MR-MINI-LEVEL-SHIFTER is a device that translate +5V to +3.3V logic or +3.3V to +5V logic. There are no external components required. This makes it perfect for embedded systems that need to interface with different logic level.

The board features innovations that set it apart from other level-shifter board. Innovations feature like on-board +3.3 voltage regulator, jumpers select direction, male and female input/output terminals and power on LED. The module can be easy to interface via male or female headers. The board is small can compact in size 2.20 x 1.70 inches.

The MR-MINI-LEVEL-SHIFTER is designed base on 74LCX245 IC. It is eight non-inverting bidirectional buffers. The device is designed for low voltage (3.3V) VCC applications with capability of interfacing to a 5V signal environment.

Features:

- +3.3V ⇔ +5V level shifter
- On-board +3.3V/500mA voltage regulator (can be use as supply power to +3.3V devices)
- Eight non-inverting bidirectional buffers
- Power on LED
- Jumpers direction selection
- Small and compact in size
- Four mounting holes on each corner
- Male and Female header inputs.

NOTE

There is an on-board +3.3V/500mA regulator provided. User only needs to supply power to +5.0V pin. +3.3V pin is an output voltage that can supply up to 500mA. DO NOT attempt to input any power to this pin. Doing so may damage the board.

Configurations:

1. Configure the board as +5.0V input and +3.3V output.

The jumper DIR must be set to position A-TO-B. Logic +5V logics are connect to side A as input and +3.3V logics are connect to side B as output. Signal logic +5V from side A is send through buffer and convert to +3.3V logic on side B.

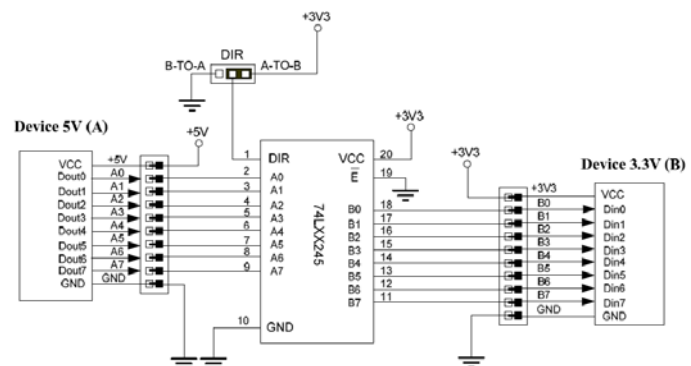

FIG 1: Jumper setting for A-TO-B direction

2. Configure the board as +3.3V input and +5.0V output.

The jumper DIR must be set to position B-TO-A. Logic +3.3V logics are connect to side B as input and +5.0V logics are connect to side A as output. Signal logic +3.3V from side B is send through

MR-MINI-LEVEL-SHIFTER™ Mini +5V ⇔ +3.3V LEVEL SHIFTER User Manual

buffer and convert to +5.0V logic on side A.

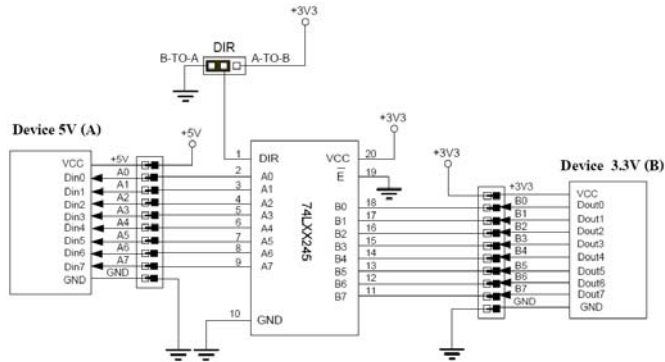
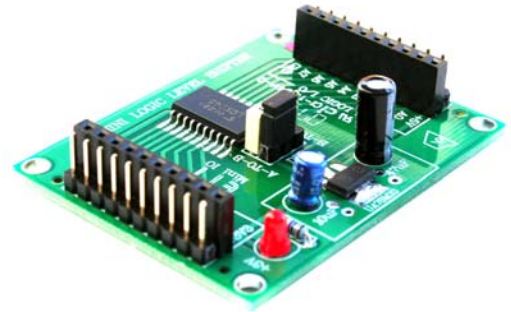

FIG 2: Jumper setting for B-TO-A direction



uResearch
© 2007 Copyright. All Rights Reserved

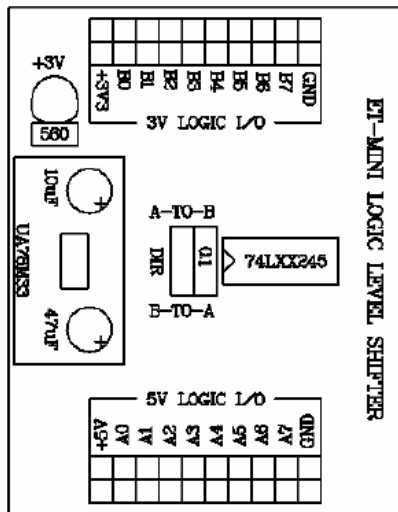

FIG 3: MR-MINI-LEVEL-SHIFTER Board Layout

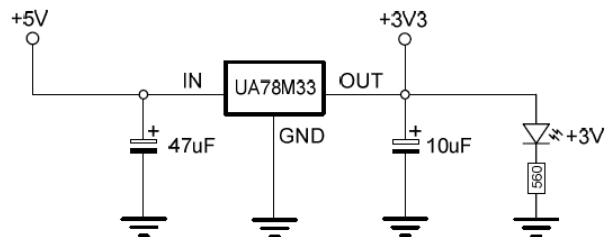
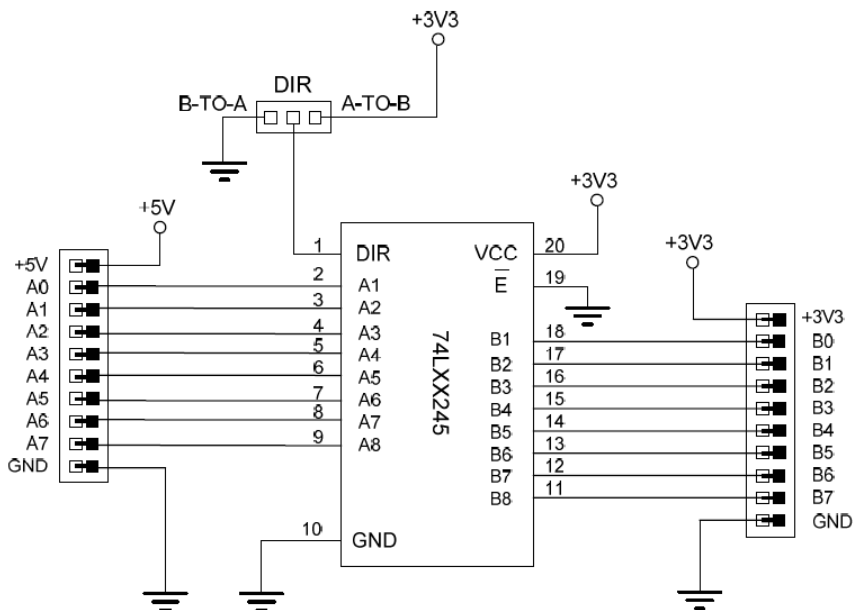

FIG 4: MR-MINI-LEVEL-SHIFTER Schematic

MR-MINI-LEVEL-SHIFTER™ Mini +5V ⇔ +3.3V LEVEL SHIFTER User Manual

Notes

Contact Us

We maintain a website where you can get information on our products, obtain literature and download support files. Visit us online at:

WWW.GRAVITECH.US

Use our online Forum or e-mail your technical support questions to support@gravitech.us. We try to respond to your questions the same day.

For sales questions or to place and order, direct your e-mails to sales@gravitech.us. Refer to our website for product pricing, shipping rates, payment instructions, and for other info we need to complete your order.

Disclaimer: MicroResearch reserves the right to modify its products or literature, or to discontinue any product at any time without prior notice. The customer is responsible for determining the suitability of any device for any application developed using MicroResearch components.

Copyright © 2007 MicroResearch
GRAVITECH GROUP WWW.GRAVITECH.US