

Lecture 3
 CPU - Data Path for Branches
 Reading - Pat. & Hen. Chap. 5, Sec. 1-6

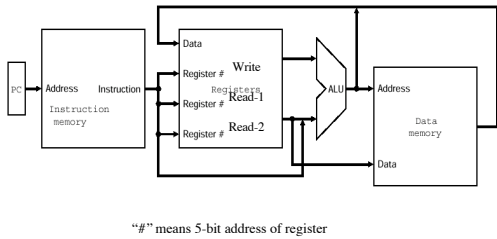

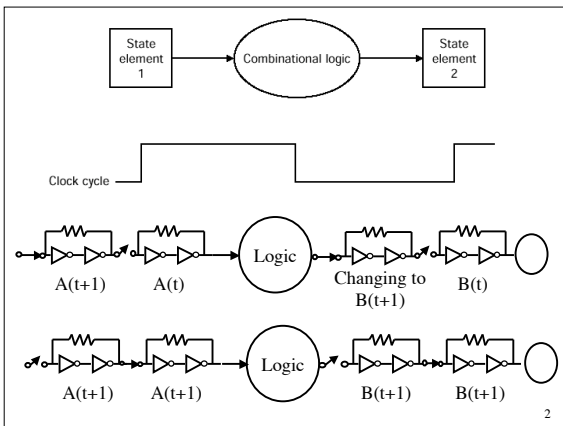

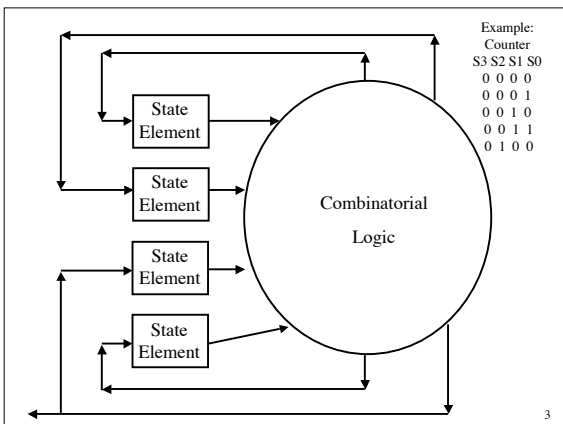

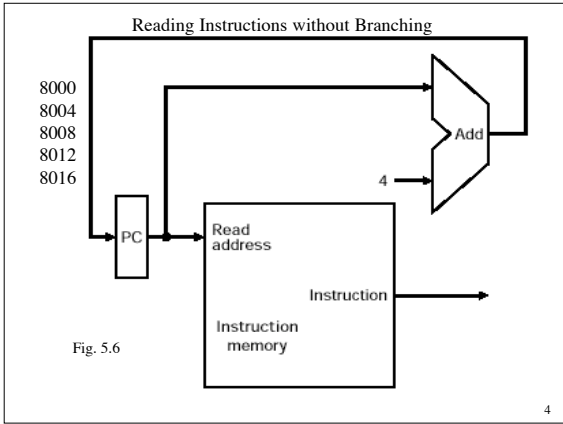

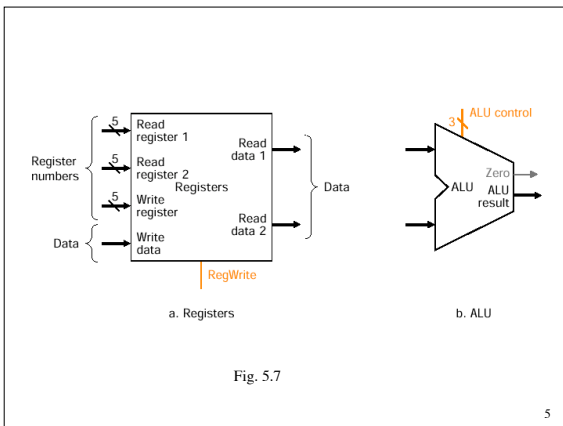

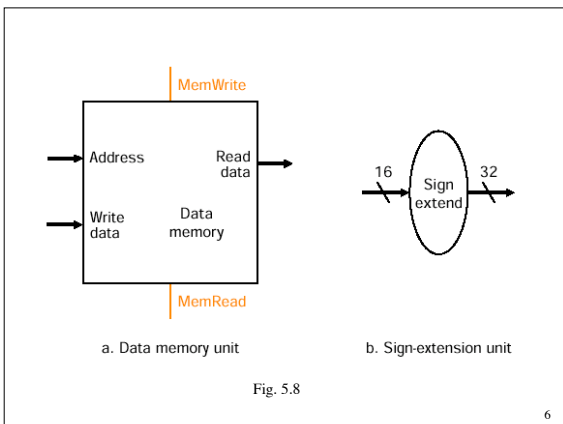

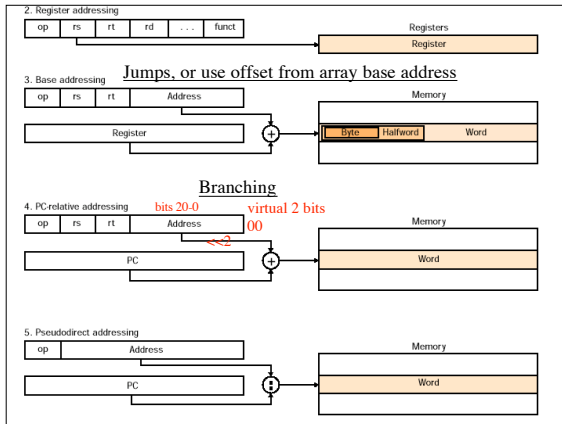

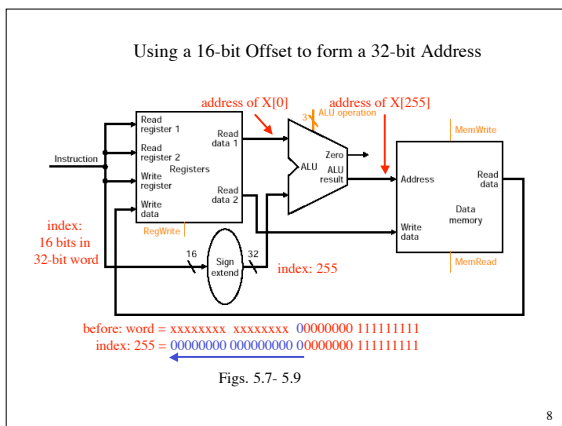

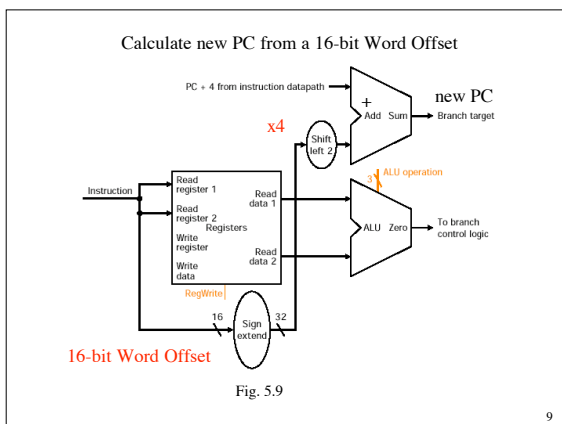

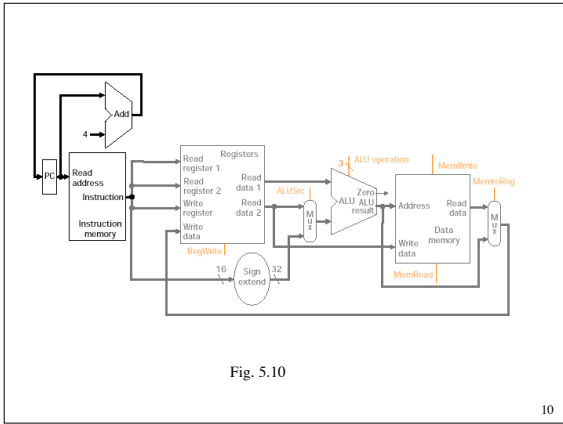

10

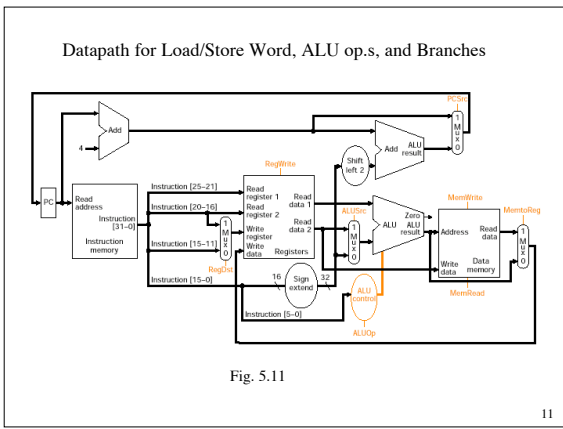

11

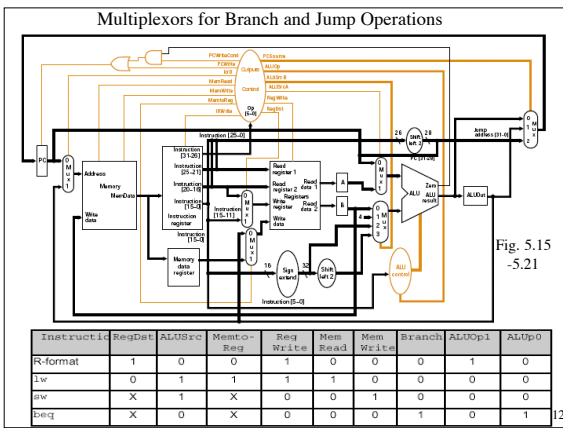

Instruction	RegDat	ALUSrc	Memto-Reg	Reg-Write	Mem-Read	Mem-Write	Branch	ALUOp1	ALUOp0
R-format	1	0	0	1	0	0	0	1	0
lw	0	1	1	1	1	0	0	1	0
sw	X	1	X	0	0	1	0	0	0
beq	X	0	X	0	0	0	1	0	1

12

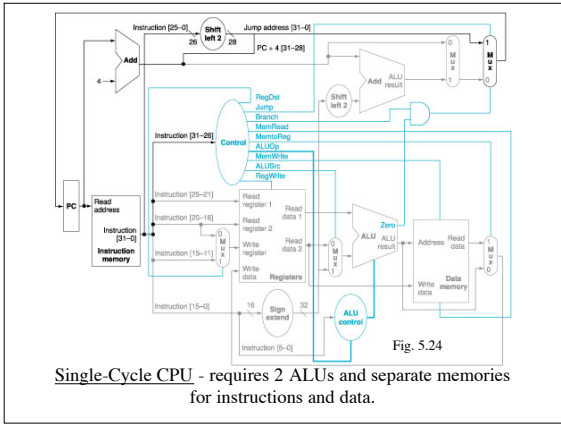

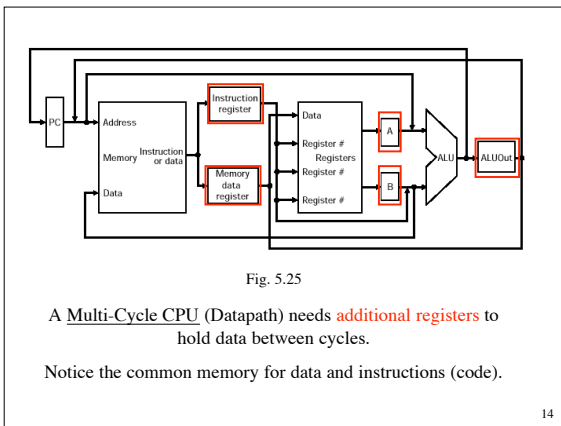

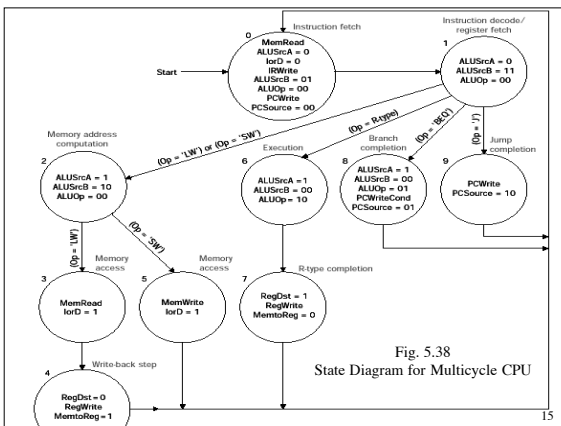

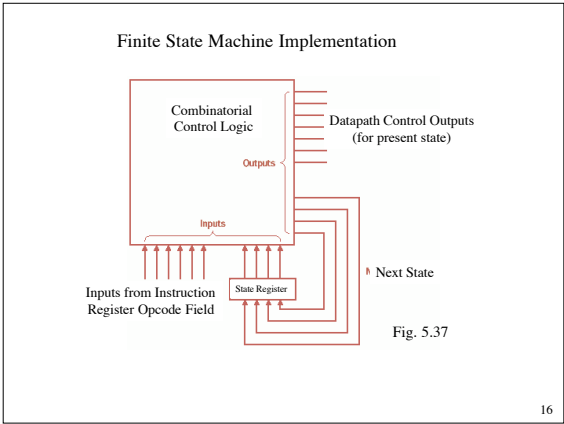

16

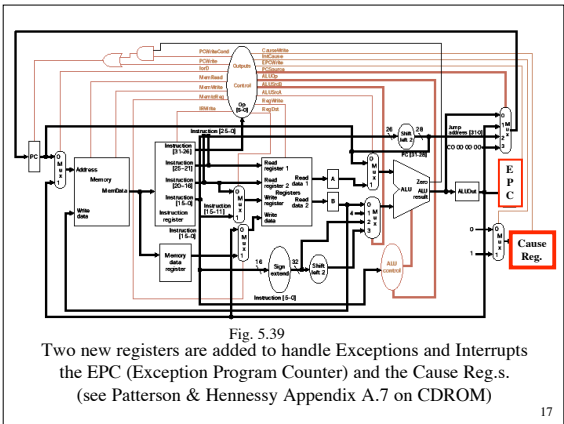

17
